

**INDEX**

of  
Developers Sub-Division Plan Requirements  
Addendums  
Standard Drawings

**GENERAL STANDARDS**

Section

General Standards . . . . .	1
Water Line Standards . . . . .	2
Sanitary Sewer Standards . . . . .	3
Drainage Design Standards . . . . .	4
General Plan Notes . . . . .	5
Roadway Street Design . . . . .	6

**ADDENDUMS**

City Water Department Rules and Regulations . . . . .	Addendum 'A'
Water Valve Operation . . . . .	Addendum 'B'
Backflow Prevention Program . . . . .	Addendum 'C'

**STANDARD DRAWINGS**

Standard Drawings . . . . .	Index
Standard Drawings . . . . .	SD-10 to SD-140

**CITY OF NEW PHILADELPHIA**  
**CHAPTER 1**  
**GENERAL STANDARDS**

1. Developer or developer's designer to obtain all required permits from local and/or state regulatory agencies having jurisdiction over these types of facilities.(I.e.: Ohio EPA for approval of water and sewer systems, and Ohio Basic Building Code, Division of Factory and Building for any pump stations, etc.) Provide the city Service Director with copies of approval letters.
2. Designer to obtain Ohio EPA Storm water permit if the scope of the project is within EPA permit limits and forward copy to city Service Director.
3. Developer's designer shall contact the city Water and Wastewater Superintendents to verify available capacity for additional loading to systems at the point of connection to the existing water or sewer system.
4. Verify with Water Superintendent whether project will fall within limits of the City's "Backflow Prevention and Cross-Connection Control Program."
5. Developer is responsible for verifying or obtaining all of the latest copies of the City's appropriate standards and standard drawings, as they are occasionally updated and revised. Incorporate the necessary standard drawings into the plan sheets, include the title and the date of the standard. This will aid the city in filing and for future reference in knowing which standard was in effect at time of construction.
6. Include date, scale, sheet title, name of project and names of persons and firm preparing plans in title block.
7. Include North arrows on appropriate plan sheets.
8. Plan and Profile sheet's horizontal scale should be no smaller than 50 scale with a vertical scale no smaller than 5 feet to the inch.
9. Show all permanent utility easements outside roadway right of way or on private property. Easements shall be 15' minimum width. All permanent easements shall be recorded at Tuscarawas County tax map office.
10. Include roadway typical sections in plan.
11. Proposed streets with properties on both sides to be fifty (50) foot minimum right of way unless previously approved by city.
12. All properties to have twenty-five (25) foot minimum frontage in accordance with city standards.
13. Include certification from Developer's designer or Engineer insuring that site soil conditions are adequate for proposed construction. If site has previously been underground mined, additional documentation regarding mining operations in the area will be required. The city's Service Director reserves the right to require additional subsurface information if the site history is questionable.

CITY OF NEW PHILADELPHIA  
CHAPTER 2  
WATER STANDARDS

1. All water mains to be 8" minimum diameter, unless looping or gridding of 6" size is accomplished in the network area. Other special conditions or circumstances might also warrant a smaller than 8" size. Any decrease in size from 8" minimum to be approved by City Water Superintendent, processing through the City's Service Directors office.
2. All water main pipe to be Class 52, Ductile Iron Pipe.
3. All ductile iron pipe to have sand bedding all around in accordance with city standard SD-116W.
4. All ductile iron water pipe installed in acidic soil will be encased with polyethylene wrap.
5. Provide a fire hydrant assembly with concrete anchor block at each dead end of waterline. See standard drawing SD-140.
6. Provide mainline water valves no more than 500 foot maximum spacing.
7. Install valve & valvebox each leg at all intersections with water lines in three or more directions.
8. Service lines: Type "K" copper, ¾"- 2" diameter.
9. Corporation Stops: "Mueller", flare fitting. (H-15000).
10. Curb Stops: "Mueller", flare to flare. (H-15204).
11. Curb Boxes: "Bibby" S7E, Croix Foundries, Inc., fig 94E - shaft screw service box.
12. 2" Roadway Box: 4½" shaft, 39"-54" round cast iron.
13. Mainline Valve: "Mueller", AWWA C-500, Double Disk, cast iron, non-rising stem, open left
14. Mainline Valve Box: 5¼" shaft, three piece valve box, 36"-48" cast iron.
15. Provide back-flow preventers above waterline main elevation of 1010.0.
16. Require privately owned individual booster pumps on all service connection lines above waterline main elevation of 1031.0.
17. No Fire Hydrants Installed above waterline main elevation of 990.0.
18. No water service will be allowed above waterline main elevation of 1077.0.
19. Stamp or etch a "W" into top of new curb over service line location during curb construction.
20. On plans, show all service tap locations, curb stop and box for each property.
21. Include brand names and model numbers along with material, construction and testing specifications on plans.
22. Maintain all clearances between water lines and sanitary sewers, both in lateral and crossing locations as required by Ohio EPA.

CITY OF NEW PHILADELPHIA  
CHAPTER 2  
WATER STANDARDS - CONTINUED

23. All tapping valves and sleeves connecting to an existing waterline will be installed by city forces. The cost of materials and labor will be billed back to the Developer.
24. All cast iron water main to have a concurrent leakage and pressure test applied after installation in accordance with AWWA C600 standards using the following formula.

$$L = .SD \sqrt{P} \div 133,200$$

Where:

- L* = allowable leakage, in gallons per hour  
*S* = length of pipe tested, in feet  
*D* = nominal diameter of the pipe, in inches  
*P* = average test pressure during the leakage test,  
in pounds per square inch (gauge)

25. Refer to City Standard Drawings for additional details.

For additional information and details, refer to addendum 'A' of this manual titled "Rules and Regulations" of the City of New Philadelphia, prepared by Gary Espenschied, dated Revised July 11,1994.



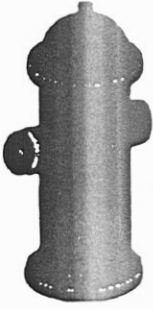

City of New Philadelphia, Ohio  
310 Mill Ave. Rear 44663  
Department of Water Utilities  
Gary A Espenschied, Superintendent



January 8, 1996

RE: Fire Systems

To Whom it may concern,

The City of New Philadelphia, Ohio, Water Department's Policy on Fire Systems are as follows:

- #1 - *The Water Department Superintendent must be notified at least seven days in advance of any tests, new installations, repairs, or service calls on a fire system within the city.*
- #2 - *No flow tests of any kind can begin before 11:00 PM or end after 5:00 AM.*
- #3 - *Emergency calls or repairs must be reported to Superintendent immediately.*

The Water Department takes static flow tests each year when flushing hydrants. This test is performed while two other hydrants are already opened. Results of these tests are available in the Superintendent's office.

If you have any questions or concerns please contact me at the above address or by phone (216) 339-2332.

*Please Note: Phone number is also FAX number.*

Sincerely,

Gary A. Espenschied  
Water Department Superintendent  
City of New Philadelphia

**CITY OF NEW PHILADELPHIA**  
**CHAPTER 3**  
**SANITARY SEWER STANDARDS**

1. Use vitrified, extra-strength pipe meeting ASTM-C700 with premium joints meeting ASTM-C425. (ODOT, Type B conduit, 706.08 with 706.12 joints)  
or  
Polyvinyl chloride (PVC) pipe and fittings conforming or exceeding ASTM-D3034, SDR 35, or ASTM-F789 for pipe 4" to 15" diameter. Use ASTM-F679, Type PS-46 with T-1 minimum wall thickness, with joints meeting ASTM-D3212 for pipe 18" to 27" diameter.  
  
All flexible elastomeric seals meeting ASTM-F477. Solvent weld joints not permitted.
2. Furnish all pipe fittings and accessories of same manufacturer as pipe. Use wye fittings for laterals, no saddles permitted.
3. Show all sewer wyes and laterals to each property line on plans.
4. All service lateral wyes may be 4" minimum if sub-division is deed restricted to single family residences, otherwise 6" for unrestricted deed, multi-family or business usage.
5. Stamp or etch a "S" into top of new curb over sewer lateral location during curb construction.
6. Maintain all clearances between sanitary sewers and water lines, both lateral and crossing locations as required by Ohio EPA.
7. Obtain approval of any proposed sanitary sewer pump station from Ohio EPA and Ohio Department of Commerce, Division of Factory and Building. Furnish copy of approval letters with plans to City Service Director at time of review request. All pump stations will have a by-pass piping arrangement to allow a portable pump hook up in case of primary pump failure. Check with city sewer department for size and type of quick disconnect fitting. In lieu of piping arrangement, a spare pump can be provided to city sewer department. All pump stations will have a visible and audible high water alarm system in case of pump failure.
8. Include construction, material and testing specifications for sanitary sewers on plans.
9. Refer to City Standard Drawings for additional details.

**CITY OF NEW PHILADELPHIA**  
**CHAPTER 4**  
**DRAINAGE DESIGN STANDARDS**

1. Prepare general hydraulic design of drainage facilities in accordance with the latest edition of the Ohio Department of Transportation "Location and Design Manual, Volume Two, Drainage Design".
2. Base storm sewer design on a 10-year storm frequency with the hydraulic grade line checked using a 25-year storm frequency. Use Manning's "n" value in accordance with the ODOT drainage manual.
3. Use a 2-year storm frequency to determine catch basin or inlet spacing on all streets. Manning's "n" used for pavement drainage is 0.015.  
  
The maximum allowable spread of flow is six (6) feet into the traveled lane.
4. The minimum size conduit for culverts, storm sewers and drive pipes is 12" .
5. All culverts (ODOT Type A conduits) shall be rigid pipe meeting the requirements of Item 603 of the ODOT Construction and Material Specifications.
6. All storm sewers (ODOT Type B & C conduits) and drive pipes (ODOT Type D conduits) shall be rigid pipe or corrugated polyethylene smooth lined pipe meeting the requirements of Item 603 of the ODOT Construction and Material Specifications.
7. Provide headwalls and pipe outlet protection as recommended in the ODOT Drainage Manual. Additionally, provide headwalls at the open ends of all drive pipes 24" diameter or greater.
8. Submit all drainage calculations including catch basin or inlet spacing calculations to the City for review and approval.
9. Include delineated drainage areas on contour mapping with all drainage calculations submitted for review.
10. Include pipe underdrains on all new roadways and detail sufficiently on plans for contractor to construct underdrains correctly.
11. Include on plans the construction and material specifications for pipe underdrain systems.
12. All drainage calculations to be signed and dated by a Registered Engineer.
13. Refer to City Standard Drawings for additional details.
14. Two (2) sets of plans and calculations shall be submitted for review.

CITY OF NEW PHILADELPHIA  
CHAPTER 5  
GENERAL PLAN NOTES

Add the following standard notes to plan in addition to other notes needed:

1. ROOF DRAIN NOTE:  
Roof drains, foundation drains, and other clean water connections to the sanitary sewer system are strictly prohibited.
  
2. PIPE UNDERDRAINS:  
Pipe underdrain material to be ODOT item 707.31, corrugated polyethylene drainage tubing, (perforated). All underdrains will outlet into proposed catch basins or storm sewer lines. A ten (10) foot section of item 603 conduit, type F, 707.33 (non-perforated) shall be used to connect underdrain to catch basin or storm sewer. Where possible, underdrain outlet elevation to be 6" minimum above invert elevation of drainage structure. Any underdrains crossing under street pavement will be ODOT item 603 conduit, type B, 707.33 (non-perforated). The underdrain trench shall be lined with filter fabric in accordance with ODOT specifications.
  
3. WATER LINES:  
Contractor to notify and coordinate with City Water and Sewer Department prior to any connections being made to the existing water or sanitary sewer systems.  
  
All mainline water valves will only be operated by City Water Department employees.
  
4. NOTIFICATION:  
Contractor to notify the City Service Director twenty four (24) hours prior to starting construction. Any time utilities are involved, other than city water and sewer, notify Ohio Utilities Protection Services at 1-800-362-2764 two working days prior to excavating.
  
5. EROSION CONTROL:  
Contractor to allow no silt or erosion to enter existing storm sewer system or water courses during construction phase. Contractor to use erosion control measures such as inlet filters and hay bales in accordance with ODOT standard Drawing MC-11, ODOT specifications and State of Ohio standards for Storm water Management, Land Development and Urban Stream Protection, second edition 1996.

City of New Philadelphia  
**CHAPTER 6**  
 Sub-Division Requirements  
 Roadway Street - Design

Requirement Description	Local Residential Streets 25 MPH	Main Collector Streets 35 MPH
Crest Vertical Curve - K factor (50' V.C. minimum length)	12	17
Sag Vertical Curve - K factor (50' V.C. minimum length)	16	24
Minimum Radius of Horizontal Curve	100.00 ft.	143.24 ft.
Maximum Degree of Horizontal Curve	57°-17'-45"	40°-00'
Maximum Degree of Curve without Superelevation	None Req'd.	40°-00'
Maximum centerline Deflection without Horizontal Curve	5°-30'	5°-30'
Maximum Percent Change in Vertical Alignment without a Vertical Curve	1.00%	1.85%
Maximum length for Roadways with Cul-de-sacs.	500 ft.	----
Maximum Percent Grades Local Streets - 25 MPH	Level Rolling Hilly	4% 8% 12%
		10% 13% 15%
Minimum Radii of Intersection Corner Returns	15 ft (Min.) 20 ft (Desired)	15 ft (Min.) 20 ft (Desired)
Angle of Intersecting Streets: (See note 1 below)	85°- 95°	85°- 95°
Sidewalk curb ramps for handicap accessibility. (Provide curb ramp at each intersection with sidewalks intended for pedestrian crossings.)	* ODOT Std. Drawing BP-7.1	* ODOT Std. Drawing BP-7.1
Intersecting Street Grades	-2.08% See note 2	-2.08% See note 2

Note 1: Maintain a tangent length of 50' minimum from centerline of intersected street to point of curve on intersecting street.

Note 2: Intersected street grade shall continue at pavement slope (-2.08%) for additional 10 foot minimum from edge of pavement. This point will be point of curvature for either a vertical crest or vertical sag rounding, length based on K factor of intersecting grades.

\* ODOT - Ohio Department Of Transportation, Standard Construction Drawings

# **ADDENDUM "A"**

# **City of New Philadelphia Water Policy**

**CHAPTER 1:** GENERAL

**CHAPTER 2:** SERVICES

213: Temporary Water Service (Inside)

214: Temporary Water Service (Outside)

**CHAPTER 3:** CHARGES & BILLING

**CHAPTER 4:** METERS

**CHAPTER 5:** HYDRANTS & FIRE SYSTEMS

**CHAPTER 6:** BACKFLOW & CROSS CONNECTION

**CHAPTER 7:** NOTIFICATIONS

CHAPTER 1:

GENERAL

---

- 101.** The Service Director may make such by-laws and regulations as deemed necessary for the safe, economical, and efficient management and protection of the water works; and such by-laws and regulations shall have the same validity as ordinances. The following rules and regulations are applicable to all licensed plumbers and contractors.
- 102.** All residential water/sewer accounts shall be in property owners name only.
- 103.** Main line and service line valves shall be opened or closed by Water Department employees ONLY. Any person who tampers with city property is in violation of ORC – 4933.22; and subject to citation.
- 104.** Water taps shall be made on main lines only by the Water Department employees. All hose bibb connections shall be installed with vacuum breaker.
- 105.** All service line locations shall be designated by the Water Department prior to tap being installed.
- 106.** The last working, whether it be the Water Department, or contractor, or plumber shall properly backfill the curb box area and replace concrete, soil or other material to match the existing condition.
- 107.** All new lines being installed shall be treated with H.T.H. (dry calcium hypochlorite) seventy percent (70%) available chlorine.
- 108.** All new lines shall have the following list completed and approved prior to consumer use:
1. Disinfection of water line.
  2. Flushed.
  3. Approved bacteria test.
  4. Hydrostatic test.
- 109.** Each lot must have its own service, and no water line shall extend from one lot to another lot, or any other piece of ground.
- 110.** Each unit of an apartment shall have its own curb valve and individual water meter. (This applies to any apartments built or developed after July 11, 1994). Any apartment built or developed prior to this date will be billed a minimum per apartment, or by consumption on meters, whichever is greater.
- 111.** All water leaks on the side of the property owner shall be repaired within a 72 hour period.
- 112.** No meter shall be pulled for “No Bill” unless water can be shut off at curb or unless Service Director and Water Superintendent sign off because of freezing or other protection reasons.
- 113.** Shared services shall be separated when plumbing is renewed or upgraded or because of low pressure or volume of water-plugging meter for shut-off.
- 114.** All requests for water turn off/on must be scheduled with water office 48 hours in advance.



- 115. Failure to comply with any part of the Water Policy will result in a service shut off.
- 116. Business hours are Monday-Friday: 8:00am – 4:00pm, (excluding major holiday), for all service/maintenance.
- 117. Scheduled non-emergency turn on/off after hours must be paid for in advance.
- 118. Someone shall be present at property before Water Department can turn water back on.
- 119. Requests for water turn on/off **after business hours** are subject to a service fee.
- 120. Connection fees must be paid when establishing new service, for new construction.
- 121. Service Fees / Connection Fees / Tap Fees, can be obtained from the Water Office.

## CHAPTER 2:

### SERVICES

---

- 201.** Any water lines being installed to connect to city-owned lines shall be started only after the Water Department has been notified a minimum of forty-eight (48) hours, (required).
- 202.** The owner must sign up and pay for a new water service in the Service Director office upon acceptance of a building permit. Charges should be paid for the service, meter, AMR, and horn; and the owner will be given the horn at that time. The meter will be installed by the city meter installer when the necessary plumbing has been completed by making an appointment through the Water Office.
- 203.** All new service shall be marked clearly at the curb line or edge of pavement; the owner shall be responsible for location of same until tap is completed. Address and lot number shall be posted on a 2' x 2' sign with the stake on lot as soon as building permit is issued.
- 204.** No new service shall be run in sewer trenches. In cases where sewer already exists, the separation must be 10' when parallel, 18" when crossing or sewer must be sleeved as per Water Superintendent. (Ten States Standard)
- 205.** No new service shall be installed in driveways or cement walkways.
- 206.** New allotments shall have all the streets and contingent curb strips rough graded prior to installation of water main and the portion of the service lines within the street right-of-way.
- 207.** Pavement of walk replacement shall meet city standard.
- 208.** All street cuts shall be made and neatly trimmed with an air hammer.
- 209.** Service curb boxes damaged by grading operations, truck, or other means, shall be charged to the appropriate contractor, plumber, or owner.
- 210.** Frozen lines shall be thawed by the Water Department on the condition that the property owner bear one-half (1/2) the cost to the city, not including labor of city employees. Frozen pipes inside a building are the property owner's total responsibility. The city will not thaw inside pipes.
- 211.** The minimum cover on water mains and services to the right-of-way line shall be four feet (4'0"). The maximum cover should be no more than five feet (5'0").
- 212.** One service line for apartments may be installed by the city to the property and then split with separate curb valves at a charge as listed at the Water Office.
- 213.** All existing outside services shall be permitted. The City reserves the right to deny any request for new water, sewer, or other utility extensions outside the corporation limits.

**214. Temporary water Service for all Construction sites.**

1. A fee of \$75.00 for residential, or \$100.00 fee for commercial, will be charged for a temporary water service for all construction sites. Address must be posted on lot before water is turned on.
2. A temporary water service will be provided for up to **120 days**, beginning the day of permit/tap fee payment. No water is permitted without valid building permit and paid tap fees.
3. After the expiration of the 120 days the water shall be shut off or a meter set. If more time is needed to complete the plumbing, a request by the contractor may be approved by the Water Superintendent and/or Service Director to continue temporary water for up to an additional 60 days.

Further extensions may be permitted in extremely unusual cases, at the discretion of the Water Superintendent.

4. Water Department personnel are the only authorized people to turn water valves on or off. Turning a water valve may result in penalty and or theft of service citation via ORC 4933.22.
5. Appointments to set a meter need to be made **5 days** in advance to assure prompt service. All appointments are made through the Water Office.
6. All turn On's and Off's for construction shall also be scheduled through the **Water Office at 330-364-4491, ext. 1211, Monday thru Friday, 8:00am to 4:30pm.**

**Emergencies after work hours call the Police Department at 330-343-4488.**

7. The following list is **allowable** uses for water under the construction and temporary water service policy:
  - Mixing of mortar, drywall compound, etc.
  - Construction site cleanup, washing hands, tools, etc.
  - Testing water and sewer lines.
  - Other necessary related construction uses discussed and approved by the Water Superintendent.
8. The following are **prohibited** uses for water under the construction and temporary water service policy:
  - Watering lawns on the property, watering any other plantings on the property, nor any adjacent property. These, or any other abuses of the temporary construction water service, shall result in immediate termination of said water service. This shall be at the discretion of the City of New Philadelphia Water Department. There shall be no refunds or credits if any part of this policy is violated. Repeated abuse of this policy may result in denying of water in the future or further actions if necessary.
9. Only city licensed contractors shall perform service connection in utility right of way.

**215. Temporary Water Service for all Construction sites **Outside City.****

1. A fee of \$150.00 for residential, or \$200.00 fee for commercial, will be charged for a temporary water service for all construction sites. Address must be posted on lot before water is turned on.
2. A temporary water service will be provided for up to **120 days**, beginning the day of permit/tap fee payment. No water is permitted without valid building permit and paid tap fees.
3. After the expiration of the 120 days the water shall be shut off or a meter set. If more time is needed to complete the plumbing, a request by the contractor may be approved by the Water Superintendent and/or Service Director to continue temporary water for up to an additional 60 days.

Further extensions may be permitted in extremely unusual cases, at the discretion of the Water Superintendent.

4. Water Department personnel are the only authorized people to turn water valves on or off. Turning a water valve may result in penalty and or theft of service.
5. Appointments to set a meter need to be made **5 days** in advance to assure prompt service. All appointments are made through the Water Office.
6. All turn On's and Off's for construction shall also be scheduled through the **Water Office at 330-364-4491, ext. 1211, Monday thru Friday, 8:00am to 4:30pm.**

**Emergencies after work hours call the Police Department at 330-343-4488.**

7. The following list is **allowable** uses for water under the construction and temporary water service policy:
  - Mixing of mortar, drywall compound, etc.
  - Construction site cleanup, washing hands, tools, etc.
  - Testing water and sewer lines.
  - Other necessary related construction uses discussed and approved by the Water Superintendent.
8. The following are **prohibited** uses for water under the construction and temporary water service policy:
  - Watering lawns on the property, watering any other plantings on the property, nor any adjacent property. These, or any other abuses of the temporary construction water service, shall result in immediate termination of said water service. This shall be at the discretion of the City of New Philadelphia Water Department. There shall be no refunds or credits if any part of this policy is violated. Repeated abuse of this policy may result in denying of water in the future or further actions if necessary.
9. Only city licensed contractors shall perform service connection in utility right of way.

CHAPTER 3:  
CHARGES & BILLING

---

- 301.** Each business unit shall be billed as referenced in Policy #110., unless established by the Water Superintendent that the unit has no water connection within the unit.
- 302.** All water charged for “water usage only” shall be metered through a separate meter. This applies to outside sprinklers and swimming pools. No deduct meters are permitted.
- 303.** Transfer of ownership.
1. When property is sold, a final reading must be scheduled for billing purposes.
  2. Until a final reading is taken, the account and billing will remain the seller’s responsibility.
  3. City preference is to have seller schedule final reading, so that a forwarding address is obtained. However, either party, (buyer or seller), may schedule the reading.
  4. Buyer must fill out an application for property within 48 hours of possession, or they risk service being shut off.
  5. The City does not receive notification of property transfers; it is the responsibility of the property owners, (buyer and seller), to transfer utility billing.
  6. In the event where a property is purchased with an outstanding balance (i.e., foreclosure, tax lien); a copy of the receipt for full payment, made at the Tuscarawas County Courthouse, must be given to the Water Office. Water service will not be restored, and utility billing cannot be transferred until full payment is received.
- 304.** A late charge of 10% of outstanding account balance will be added after due date. Payments must be **received** by the Water Office on the stated due date, by end of business hours, to avoid late charge.
- 305.** Failure to receive bill does not relinquish responsibility for payment when due.
- 306.** A \$35.00 fee will be applied to account balance for all NSF checks, automatic payments, bank drafts and credit/debit card payments.
- 307.** Water Office CANNOT ACCEPT post-dated, unsigned, or incomplete checks as valid payment.
- 308.** Any person/account having two (2) NSF checks within a twelve (12) month period, must make payment with cash or money order at the Water Office only.
- 309.** If payment to avoid shut off is returned for any reason, service will be immediately turned off at the curb. A \$50 service fee plus a \$35 returned check fee will be applied to the outstanding balance. Balance must be paid, in full, with cash for service to be restored.
- 310.** No allowance shall be made to any consumer of water on account of leakage in any water pipe, tank, or other apparatus within its control.
- 311.** If a bill is found to have been improperly calculated, a credit or charge shall be made by the next billing.

**312.** A \$50 charge will be applied to balances on all Final Notice Bills/Shutoff's if payment is not received at the WATER OFFICE before stated shut off day, by end of business hours.

**313.** If necessary, payment arrangements are at the discretion of the Water Office Manager, with Water Superintendent's approval.

## CHAPTER 4:

### METERS

---

- 401.** All services shall be flushed out before installation of meters. On all renewal services meters should be removed prior to flushing of new line.
- 402.** No outside meter pits shall be allowed.
- 403.** Meter must be located immediately from where water service enters the structure. Meter location must be readily accessible, not located behind any object such as water heater, furnace, washer, dryer, etc.
- 404.** The City shall have access to the premises to inspect, repair, install or replace meter within 48 hours.
- 405.** No meters shall be installed upstream adjacent to the meter.
- 406.** An inside shut-off valve shall be installed upstream adjacent to the meter.
- 407.** New constructions shall have shut-off valve installed immediately before and after water meter is installed; at point where water line enters structure.
- 408.** Renewal of old plumbing requires shut-off valves before and after meter or where there is no drain in the vicinity of the meter, or it is not feasible to drain the meter, valves shall be placed on either side of the meter. This applies when remodeling is being done which necessitates changing the location of the meter.
- 409.** No by-pass lines shall be allowed around residential meters.
- 410.** Each Customer is responsible for maintaining the plumbing at the service address in a condition sufficient to allow the Water Department to access, remove or exchange the water meter. If it is necessary for the Water Department to access, remove or exchange the meter and the plumbing is in the opinion of the Superintendent of the Water Department or designee not in good working condition, the Customer shall repair the plumbing within thirty (30) days of written request by the Water Department and agrees to hold the Water Department harmless for any damage to plumbing which might result from the access, removal, or exchange.
- 411.** Meters shall be installed upstream of pressure-reducing valves.
- 412.** All lines shall have appropriate copper ground wires bypassing the meter.
- 413.** Provisions shall be made for installation of wiring for the remote reader as approved by the Water Department employees.
- 414.** All new water meters shall be remote-reading wherever possible.
- 415.** All water meters shall be provided by the Water Department at the consumer's expense. No other meters shall be acceptable.

**416.** Residential installations of spec, SR2 Water Meters, For Cold Water Meters, Encoder (ECR and ECR/WP) Type Remote, Displacement Type with Direct Read Registers, 5/8" x 3/4" – 2" SR sizes, are required to be installed for new installations and anytime significant plumbing upgrades are being performed to existing installations, as determined by the Water Superintendent or designee.



CHAPTER 5:  
HYDRANTS & FIRE SYSTEMS

---

- 501.** Hydrants shall be opened only by Water Department employees, as per City Codified Ordinance Chapter 946.
- 502.** The Water Department Superintendent must be notified at least seven (7) days in advance of any tests, new installations, repairs, or service calls on a fire system within the city, per City Codified Ordinance 946.
- 503.** No flow tests of any kind can begin before 11:00 PM or end after 5:00 AM.
- 504.** Emergency calls or repairs must be reported to the Superintendent immediately.

CHAPTER 6:  
BACKFLOW & CROSS CONNECTIONS

---

- 601.** Wells and potable city water must have separate lines with approved backflow prevention.
- 602.** All sprinkler systems, boiler systems, water air conditioners, or other non-potable systems shall have appropriate backflow preventers as approved by the Ohio E.P.A. and Water Superintendent, or designee.
- 603.** All houses above 1010ft. elevation shall have backflow preventers installed by a plumber before the meters are installed.
- 604.** All backflow devices must be inspected annually by an approved licensed plumber.
- 605.** An approved plumber list can be obtained at the Water Office.

CHAPTER 7:  
NOTIFICATIONS

---

**701.** Notification of property or water service address for meter change or inspections:

- a. Phone call/leave message
- b. Green Tag
- c. Letter – Certified mail.
- d. If appointment is not made within 7 days water utilities will be SHUT OFF.

**702.** Bad pipes

- a. 30 day letter
- b. 5 day letter – Certified mail.
- c. If appointment not made then SHUT OFF.

**703.** Non-payment:

- a. 1<sup>st</sup> bill
- b. 2<sup>nd</sup> bill
- c. Lien placed on shared services.
- d. SHUT OFF – Water bill must be paid in full before water can be turned back on.

**704.** NSF Checks:

- a. Red tag or phone call or BOTH
- b. SHUT OFF – Must be paid in full and by cash or certified check before water can be turned back on.  
(Paid in full = Total account balance + \$35/NSF fee + \$50 service fee.)
- c. \*After 2 NSF checks in a 12 month period, customer must make future payments in cash or money order.\*

**705.** Application needed:

- a. Red Tag
- b. If application is not received within 2 days of Red Tag, service will be SHUT OFF.

# **ADDENDUM "B"**

LEO BENJAMIN, MAYOR  
JOHN W. STEVENSON, SERVICE DIRECTOR  
DAVID SISSON, SAFETY DIRECTOR



TREVOR BUEHLER, LAW DIRECTOR  
STEPHEN A. SMITH, CITY AUDITOR  
SAM BAIO, CITY TREASURER

## CITY of NEW PHILADELPHIA, OHIO

TELEPHONE (216) 364-4491

166 EAST HIGH AVENUE

May 15, 1987

To: All Plumbers licensed in the City of New Philadelphia

This is a reminder that all main line, and service valves be opened or closed by Water Department employees only.

Thank you for your cooperation concerning this matter.

Sincerely,

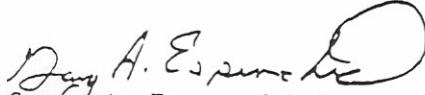
  
Gary A. Espenschied  
Water Superintendent

Sam Baio  
Service Director  
CITY OF NEW PHILADELPHIA

*An Equal Opportunity Employer*

# ADDENDUM "C"

TIM A. HURST, MAYOR  
SAMUEL J. BAIO, SERVICE DIRECTOR  
ROBERT O. STEMPLE, SAFETY DIRECTOR



MICHAEL C. JOHNSON, LAW DIRECTOR  
BETTY L. GLEITSMAN, CITY AUDITOR  
DONNA L. GARDNER, CITY TREASURER

## *CITY of NEW PHILADELPHIA, OHIO*

166 EAST HIGH AVENUE

NEW PHILADELPHIA, OHIO 44663-2568

TELEPHONE (216) 364-4491

TO WHOM IT MAY CONCERN:

On July 8, 1991, an ordinance, number 43-91, was passed by Council of the City of New Philadelphia, providing for an enlarged method of cross-connection control and quality protection of the public water system.

This ordinance requires the Water Department Superintendent to order the installation of backflow protection on any water service line that presents either an actual or potential hazard to the public water system.

Since the ordinance becomes a part of the rules and regulations governing the operation of the New Philadelphia Water Department, it shall be in effect in all areas served by the Water Department.

Our backflow prevention program will eventually effect ALL service liens that present a hazard; this means those which have been in existence for a good many years as well as new or proposed branches.

The purpose of this letter is two - fold. One, we want to notify you that the program is now fully and lawfully in effect; and two, we want you as an interested person to be fully aware of the program so that you will consider the need for the proper backflow protective device in the design and installation of the water service for any facility on which you may currently be working.

The type of protective device required will depend on the degree of hazard involved. It will be in agreement with the Ohio Environmental Protection Agency Regulations 3745-95-01 thru 08 and 3745-99-01. The protective device itself must be approved by the Water Department Superintendent and the Ohio E.P.A. The protective device itself must be installed in a location with clearances, available drainage, temperature limits, accessibility, etc., subject to the approval of the Water Department Superintendent.

*An Equal Opportunity Employer*

As a general guideline, an approved backflow prevention device shall be required on each water service branch serving premises where the following conditions exist.

1. Premises having an auxiliary water supply, unless such auxiliary supply is accepted as an additional source by the water purveyor and the source is approved by the Department of Health.
2. Premises on which any substance is handled in such a fashion as to create an actual or potential hazard to the public potable water system. This shall include premises having sources or systems containing process fluids or waters originating from the public potable water system which are no longer under the sanitary control of the water purveyor.
3. Premises having internal cross - connections that, in the judgment of the water purveyor, are not correctable or intricate to determine whether or not cross - connections exist.
4. Premises where, because of security requirements or other prohibitions or restrictions, it is impossible or impractical to make a complete cross - connection survey.
5. Premises having a repeated history of cross - connections being established or reestablished.

The following types of facilities shall normally require the designated backflow prevention devices. This list is also presented as a guideline, and should not be construed as being final or complete. Each case will be judged by its own merit.

Abbreviations used are as follows:

- A.G. - Air Gap Separation
- R.P. - Reduced Pressure Principle Backflow Prevention Device
- D.C. - Double Check Valve Assembly
- V.B. - Atmospheric Vacuum Breaker

Type of Facility	Type of Protection
Car Washes	A.G. or R.P.
Chemical Plants	A.G. or R.P.
Film Laboratories or Developing Facilities	A.G. or R.P.
Food or Beverage Processing Plants	D.C.
Hospitals, Clinics, Medical Buildings	A.G. or R.P.
Laboratories	A.G. or R.P.
Laundries and Dry Cleaners (Health Hazard)	A.G. or R.P.
Machine Tool Plants (Health Hazard)	A.G. or R.P.
Metal Processing or Production (Health Hazard)	A.G. or R.P.



Metal Plating Plants	A.G. or R.P.
Nursing Homes, Convalescent Homes, Extended Care Homes, Rest Homes	A.G. or R.P.
Packing Houses	A.G. or R.P.
Paper Products Plants	A.G. or R.P.
Petroleum Processing Plants	A.G. or R.P.
Petroleum Storage Plants or Yards (Health Hazard)	A.G. or R.P.
Petroleum Storage Plants or Yards (No Health Hazard)	D.C.
Pharmaceutical or Cosmetic Plants	A.G. or R.P.
Piers, Docks or Waterfront Facilities	A.G. or R.P.
Power Plants and Substations	A.G. or R.P.
Radioactive Material Plants	A.G. or R.P.
Rendering Plants	A.G. or R.P.
Schools with Laboratories	A.G. or R.P.
Sprinkling or Irrigation Systems	D.C. or V.B.
Swimming Pools with Direct Connection	D.C. or V.B.
Sewage Treatment Plants	A.G. or R.P.
Sewage Pumping Station (Health Hazard)	A.G. or R.P.
Sewage Pumping Station (No Health Hazard)	D.C.
Premises Having Water Recirculating Systems and Pumps (Health Hazard)	A.G. or R.P.
Premises Having Water Systems Filled With Antifreeze Solutions	A.G. or R.P.
Premises Having Boilers or Cooling Systems where Toxic Conditioners are used	A.G. or R.P.
Premises Having Water Storage Tanks, Reservoirs, Ponds or Wells, etc.	A.G. or R.P.
Veterinary Establishments	A.G. or R.P.
Others as Specified by the Water Department Superintendent	A.G. or R.P.

If you have any questions concerning this letter, please write to, or call:

Gary Espenschied  
 Superintendent of Water Distribution  
 339-2332  
 339-2883

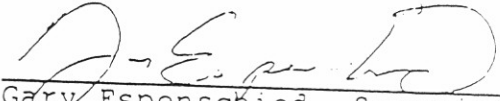
  
 Gary Espenschied, Superintendent  
 New Philadelphia Water Dept.

Chapter 3745-95 of the Ohio Administrative Code replaces and is essentially the same as regulation HE-34 which was adopted by the Public Health Council of the Ohio Department of Health on April 15, 1972, and became effective on July 1, 1972.

CHAPTER 3745-95 BACKFLOW PREVENTION AND  
CROSS-CONNECTION CONTROL

3745-95-01	Definitions
3745-95-02	Cross-connections
3745-95-03	Surveys and investigations
3745-95-04	Where protection is required
3745-95-05	Type of protection required
3745-95-06	Backflow prevention devices
3745-95-07	Booster pumps
3745-95-08	Violations
3745-95-01	Definitions

As used in this Chapter of the Administrative Code:

- (A) "Air gap separation" means the unobstructed vertical distance through the free atmosphere between the lowest opening from any pipe or faucet supplying water to a tank, plumbing fixture or other device and the flood level rim of the receptacle.
- (B) "Approved" means that a backflow prevention device or method has been accepted by the supplier of water and the director as suitable for the proposed use.
- (C) "Auxiliary water system" means any water system on or available to the premises other than the public water system and includes the water supplied by the system. These auxiliary waters may include water from another supplier's public water system; or water from a source such as wells, lakes, or streams; or process fluids; or used water. They may be polluted or contaminated or objectionable or constitute a water source or system over which the supplier of water does not have control.
- (D) "Backflow" means the flow of water or other liquids, mixture or substances into the distributing pipes of a potable water supply from any source other than the intended source of the potable water supply.
- (E) "Backflow prevention device" means any device, method, or type of construction intended to prevent backflow into a potable water system.
- (F) "Consumer" means the owner or person in control of any premises supplied by or in any manner connected to a public water system.

- (G) "Consumer's water system" means any water system, located on the consumer's premises, supplied by or in any manner connected to a public water system. A household plumbing system is considered to be a consumer's water system.
- (H) "Contamination" means an impairment of the quality of the water by sewage or process fluid or waste to a degree which could create an actual hazard to the public health through poisoning or through spread of disease by exposure.
- (I) "Cross-connection" means any arrangement whereby backflow can occur.
- (J) "Degree of hazard" is a term derived from an evaluation of the potential risk to health and the adverse effect upon the potable water system.
- (K) "Director" means the director of environmental protection or his duly authorized representative.
- (L) "Double check valve assembly" means an assembly composed of two single, independently acting, check valves including tightly closing shutoff valves located at each end of the assembly and suitable connections for testing the water-tightness of each check valve.
- (M) "Health hazard" means any condition, device, or practice in a water system or its operation that creates, or may create, a danger to the health and well-being of users. The word "severe" as used to qualify "health hazard" means a hazard to the health of the user that could reasonably be expected to result in significant morbidity or death.
- (N) "Interchangeable connection" means an arrangement or device that will allow alternate but not simultaneous use of two sources of water.
- (O) "Non-potable water" means water not safe for drinking, personal, or culinary use.
- (P) "Person" means the state, any political subdivision, public or private corporation, individual, partnership, or other legal entity.
- (Q) "Pollution" means the presence in water of any foreign substance that tends to degrade its quality so as to constitute a hazard or impair the usefulness or quality of the water to a degree which does not create an actual hazard to the public health but which does adversely and unreasonably affect such waters for domestic use.
- (R) "Potable water" means water which is satisfactory for drinking, culinary, and domestic purposes and meets the requirements of the environmental protection agency.

- (S) "Process fluids" means any fluid or solution which may be chemically, biologically or otherwise contaminated or polluted in a form or concentration such as would constitute a health, pollutional, or system hazard if introduced into the public or a potable consumer's water system. This includes, but is not limited to:
- (1) Polluted or contaminated waters;
  - (2) Process waters;
  - (3) Used waters originating from the public water system which may have deteriorated in sanitary quality;
  - (4) Cooling waters;
  - (5) Contaminated natural waters taken from wells, lakes, streams, or irrigation systems;
  - (6) Chemicals in solution or suspension;
  - (7) Oils, gases, acids, alkalis, and other liquid and gaseous fluids used in industrial or other processes, or for fire fighting purposes.
- (T) "Public water system" has the meaning ascribed to such term in rule 3745-81-01 of the Administrative Code.
- (U) "Reduced pressure principle backflow prevention device" means a device containing a minimum of two independently acting check valves together with an automatically operated pressure differential relief valve located between two check valves. During normal flow and at the cessation of normal flow, the pressure between these two checks shall be less than the supply pressure. In case of leakage of either check valve, the differential relief valve, by discharging to the atmosphere, shall operate to maintain the pressure between the check valves at less than the supply pressure. The unit must include tightly closing shutoff valves located at each end of the device, and each device shall be fitted with properly located test cocks.
- (V) "Service connection" means the terminal end of a service line from the public water system. If a meter is installed at the end of the service, then the service connection means the downstream end of the meter.
- (W) "Supplier of water" means the owner or operator of a public water system.
- (X) "System hazard" means a condition posing an actual or potential threat of damage to the physical properties of the public water system or a potable consumer's water system.

- (Y) "Pollutional hazard" means a condition through which an aesthetically objectionable or degrading material not dangerous to health may enter the public water system or a potable consumer's water system.
- (Z) "Used water" means any water supplied by a supplier of water from a public water system to a consumer's water system after it has passed through the service connection and is no longer under the control of the supplier.

(Adopted October 9, 1980; effective November 26, 1980.)

3745-95-02 Cross-connections

- (A) No person shall install or maintain a water service connection to any premises where actual or potential cross-connections to a public water system or a potable consumer's water system may exist unless such actual or potential cross-connections are abated or controlled to the satisfaction of the supplier of water.
- (B) No person shall install or maintain any connection whereby water from an auxiliary water system may enter a public water system or potable consumer's water system unless the auxiliary water system and the method of connection and use of such system shall have been approved by the supplier of water and by the director as required by section 6109.13 of the Revised Code.

(Adopted October 9, 1980; effective November 26, 1980.)

3745-05-03 Surveys and investigations

- (A) The supplier of water shall conduct or cause to be conducted periodic surveys and investigations, of frequency acceptable to the director, of water use practices within a consumer's premises to determine whether there are actual or potential cross-connections to the consumer's water system through which contaminants or pollutants could backflow into the public water system.
- (B) The supplier of water, or his authorized representative, shall have the right to enter premises served by the public water system at all reasonable times for the purpose of making surveys and investigations of water use practices within the premises.
- (C) On request by the supplier of water, or his authorized representative, the consumer shall furnish the supplier of water, or his authorized representative, information on water use practices within the consumer's premises.
- (D) Paragraph (A) of this rule does not relieve the consumer of the responsibility for conducting, or causing

to be conducted, periodic surveys of water use practices on his premises to determine whether there are actual or potential cross-connections in the consumer's water system through which contaminants or pollutants could backflow into a public water system or a potable consumer's water system.

(Adopted October 9, 1980; effective November 26, 1980.)

3745-95-04 Where protection is required

- (A) An approved backflow prevention device shall be installed on each service line to a consumer's water system serving premises, where in the judgment of the supplier of water or the director, a health, pollutional, or system hazard to the public water system exists.
- (B) An approved backflow prevention device shall be installed on each service line to a consumer's water system serving premises where the following conditions exist:
  - (1) Premises having an auxiliary water system, unless such auxiliary system is accepted as an additional source by the supplier of water and the source is approved by the director;
  - (2) Premises on which any substance is handled in such a fashion as to create an actual or potential hazard to a public water system. This shall include premises having sources or systems containing process fluids or waters originating from a public water system which are no longer under the control of the supplier of water;
  - (3) Premises having internal cross-connections that, in the judgment of the supplier of water, are not correctable, or intricate plumbing arrangements which make it impracticable to determine whether or not cross-connections exist;
  - (4) Premises where, because of security requirements or other prohibitions or restrictions, it is impossible or impractical to make a complete cross-connection survey;
  - (5) Premises having a repeated history of cross-connections being established or re-established
  - (6) Others specified by the director.



(C) An approved backflow prevention device shall be installed on each service line to a consumer's water system serving, but not necessarily limited to, the following types of facilities unless the director determines that no health, pollutional, or system hazard to the public water system exists:

- (1) Hospitals, mortuaries, clinics, nursing homes;
- (2) Laboratories;
- (3) Piers, docks, waterfront facilities;
- (4) Sewage treatment plants, sewage pumping stations, or storm water pumping stations;
- (5) Food or beverage processing plants;
- (6) Chemical plants;
- (7) Metal plating industries;
- (8) Petroleum processing or storage plants;
- (9) Radioactive material processing plants or nuclear reactors;
- (10) Car washes;
- (11) Others specified by the director.

(D) An approved backflow prevention device shall be installed at any point of connection between a public water system or a potable consumer's water system and an auxiliary water system, unless such auxiliary system is acceptable as an additional source by the supplier of water and the source is approved by the director.

(Adopted October 9, 1980, effective November 26, 1980.)

3745-95-05 Type of protection required

(A) The type of protection required under paragraphs (A), (B), and (C) of Rule 3745-95-04 of the Administrative Code shall depend on the degree of hazard which exists as follows:

- (1) An approved air gap separation shall be installed where a public water system may be contaminated with substances that could cause a severe health hazard;
- (2) An approved air gap separation or an approved reduced pressure principle backflow prevention device shall be installed where a public water system may be contaminated with any substance that could cause a system or health hazard;
- (3) An approved air gap separation or an approved reduced pressure principle backflow prevention device or an approved double check valve assembly shall be installed where a public water system may be polluted with any substance that could cause a pollutional hazard.

- (B) The type of protection required under paragraph (D) of rule 3745-95-04 of the Administrative Code shall be an approved air gap separation or an approved interchangeable connection.
- (C) Where an auxiliary water system is used as a secondary source of water for a fire protection system, the provisions of paragraph (B) of this rule for an approved air gap separation or an approved interchangeable connection may be waived by the director, provided:
  - (1) At premises where the auxiliary water system may be contaminated with substances that could cause a system or health hazard, a public water system or a potable consumer's water system shall be protected against backflow by installation of an approved reduced pressure principle backflow prevention device;
  - (2) At all other premises, a public water system or a potable consumer's water system shall be protected against backflow by installation of either an approved reduced pressure principle backflow prevention device or an approved double check valve assembly;
  - (3) A public water system or a potable consumer's water system shall be the primary source of water for the fire protection system;
  - (4) The fire protection system shall be normally filled with water from a public water system or a potable consumer's water system;
  - (5) The water in the fire protection system shall be used for fire protection only, with no other use of water from the fire protection system downstream from the approved backflow prevention device.

(Adopted October 9, 1980; effective November 26, 1980.)

3745-95-06 Backflow prevention devices

- (A) Any backflow prevention device required by rules 3745-95-04 and 3745-95-05 of the Administrative Code shall be of a model or construction approved by the supplier of water and the director.
- (B) Any backflow prevention device required by rules 3745-95-04 and 3745-95-05 of the Administrative Code shall



be installed at a location and in a manner approved by the supplier of water and shall be installed by and at the expense of the water consumer. In addition, any backflow prevention device required by paragraphs (B) and (C) of rule 3745-95-05 of the Administrative Code shall be installed at a location and in a manner approved by the director as required by section 6109.13 of the Revised Code.

- (C) It shall be the duty of the consumer, on any premises on which backflow prevention devices required by rules 3745-95-04 and 3745-95-05 of the Administrative Code are installed, to have thorough inspections and operational tests made of the devices at such intervals and in such manner as may be reasonably required by the supplier of water or the director. ~~These inspections and tests shall be at the expense of the water consumer and shall be performed by the supplier of water~~ or a person approved by the supplier as qualified to inspect and test backflow prevention devices. It shall be the duty of the supplier of water to see that these tests and inspections are made. ~~These devices shall be repaired, overhauled or replaced at the expense of the consumer whenever they are found to be defective.~~ Records of such inspections, tests, repairs and overhaul shall be kept by the consumer and made available to the supplier of water.
- (D) Existing backflow prevention devices approved by the supplier of water or the director prior to the effective date of this rule and which are properly maintained shall, except for inspection, testing, and maintenance requirements, be excluded from the requirements of paragraphs (A) and (B) of this rule if the supplier of water and the director are assured that the devices will satisfactorily protect the public water system.

(Adopted October 9, 1980; effective November 26, 1980.)

3745-95-07     Booster pumps

- (A) No person shall install or maintain a water service connection to any premises where a booster pump has been installed on the service line to or within such premises, unless such booster pump is equipped with a low pressure cut-off designed to shut-off the booster pump when the pressure in the service line on the suction side of the pump drops to ten pounds per square inch gauge or less.
- (B) It shall be the duty of the water consumer to maintain the low pressure cut-off device in proper working order and to certify to the supplier of water, at least once a year, that the device is operable.

(Adopted October 9, 1980; effective November 26, 1980.)

- (A) The supplier of water shall deny or discontinue, after reasonable notice to the occupant thereof, the water service to any premises wherein any backflow prevention device required by this chapter is not installed, tested and maintained in a manner acceptable to the supplier of water, or if it is found that the backflow prevention device has been removed or by-passed, or if an unprotected cross-connection exists on the premises or if a low pressure cut-off required by rule 3745-95-07 of the Administrative Code is not installed and maintained in working order, or if the supplier of water or the director, or the authorized representative of either, is denied entry to determine compliance with this chapter of the Administrative Code.
- (B) Water service to such premises shall not be restored until the consumer has corrected or eliminated such conditions or defects in conformance with this chapter of the Administrative Code, and to the satisfaction of the supplier of water.

(Adopted October 9, 1980; effective November 26, 1980.)

#### CHAPTER 3745-99 MISCELLANEOUS WATER SUPPLY RULES

##### 3745-99-01 Yard Hydrants

The installation of yard hydrants where water is available or accessible for drinking or culinary purposes and having drip openings below ground surface is prohibited unless such hydrants are equipped with approved devices to prevent entrance of ground water into chambers connected with the water supply.

(Adopted October 9, 1980; effective November 26, 1980.)

#### OHIO BUILDING CODE

Chapter 4101:2-51 (the Ohio Plumbing Code) of the Ohio Administrative Code, entitled Plumbing, is part of the Ohio Basic Building Code and contains the following rules that are directly concerned with backflow prevention and cross-connection control:

- 4101:2-51-33 Water supply
- 4101:2-51-36 Water storage tanks
- 4101:2-51-38 Backflow
- 4101:2-51-76 Test of water supply system

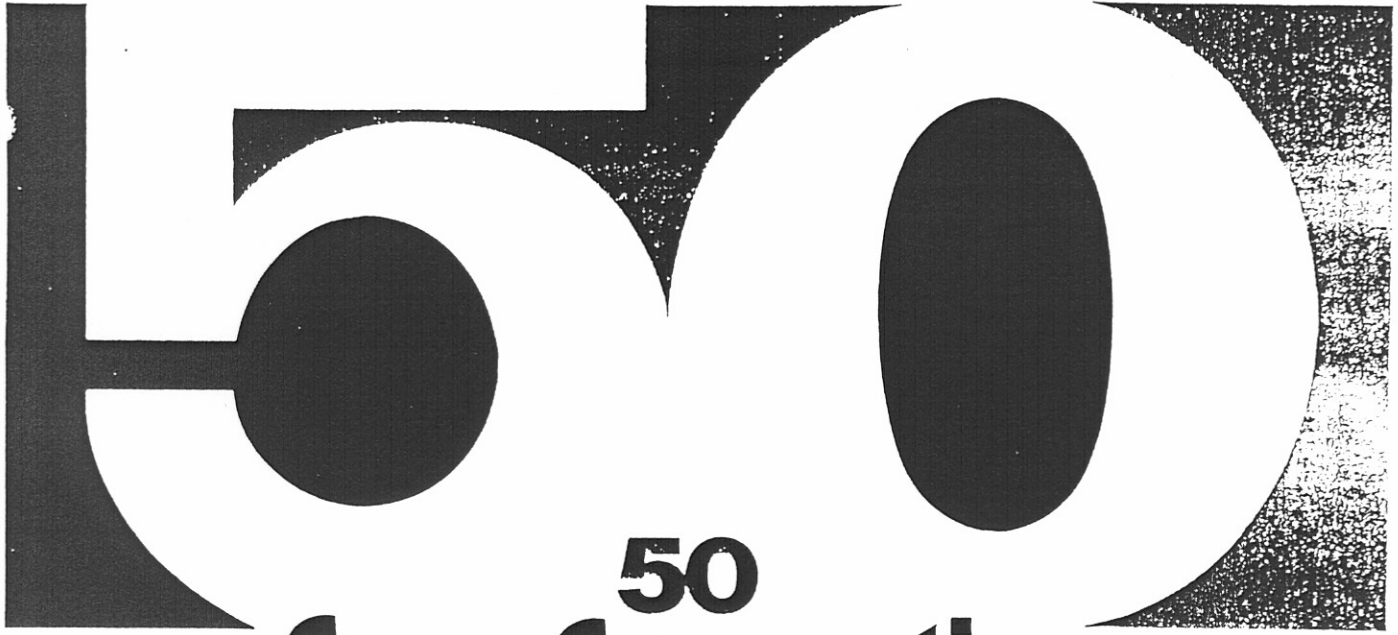

**50  
Cross-Connection  
Questions,  
Answers,  
& Illustrations**

Relating To  
**Backflow Prevention Products**  
and  
**Protection of  
Safe Drinking Water Supply**

Prepared by



815 Chestnut Street, North Andover, MA 01845-6098 USA  
Tel. (508) 688-1811 Fax: (508) 794-1848  
Watts Industries (Canada) Inc.  
Tel. (905) 851-8591 Fax: (905) 851-8788  
Watt Industries (Europe) BV Fax: +31-8338-54192  
Watts Ocean BV Fax: +31-8338-52073

# 1 What is back-siphonage?

Back-siphonage is the reversal of normal flow in a system caused by a negative pressure (vacuum or partial vacuum) in the supply piping.

# 2 What factors can cause back-siphonage?

Back-siphonage can be created when there is stoppage of the water supply due to nearby fire-fighting, repairs or breaks in city main, etc. The effect is similar to the sipping of an ice cream soda by inhaling through a straw, which induces a flow in the opposite direction.



# 3 What is backpressure backflow?

Backpressure backflow is the reversal of normal flow in a system due to an increase in the downstream pressure above that of the supply pressure.

# 4 What factors can cause a backpressure-backflow condition?

Back pressure-backflow is created whenever the downstream pressure exceeds the supply pressure which is possible in installations such as heating systems, elevated tanks, and pressure-producing systems. An example would be a hot water space-heating boiler operating under 15-20 lbs. pressure coincidental with a reduction of the city water supply below such pressure (or higher in most commercial boilers). As water tends to flow in the direction of least resistance, a back-pressure-backflow condition would be created and the contaminated boiler water would flow into the potable water supply.

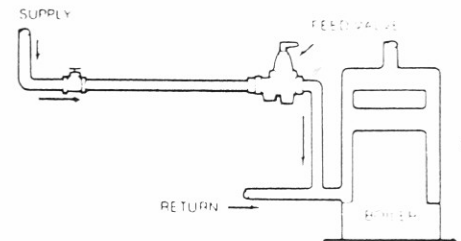

# 5 What is a cross connection?

A cross connection is a direct arrangement of a piping line which allows the potable water supply to be connected to a line which contains a contaminant. An example is the common garden hose attached to a sill cock with the end of the hose lying in a cesspool. Other examples are a garden hose attached to a service sink with the end of the hose submerged in a tub full of detergent, supply lines connected to bottom-fed tanks, supply lines to boilers.

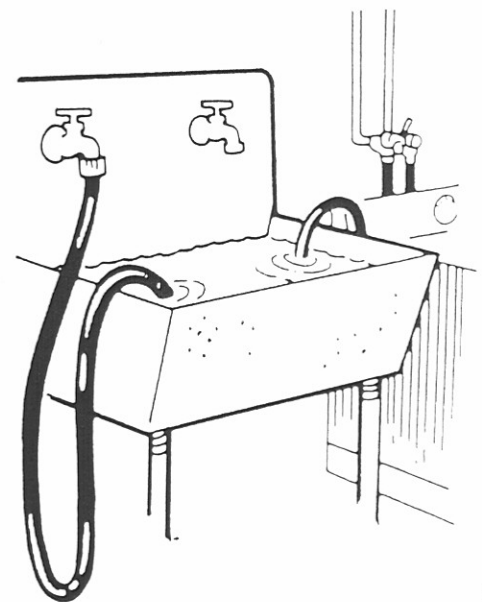

# 6 What is the most common form of a cross connection?

Ironically, the ordinary garden hose is the most common offender as it can be easily connected to the potable water supply and used for a variety of potentially dangerous applications.

## 7 What is potentially dangerous about an unprotected sill cock?

The purpose of a sill cock is to permit easy attachment of a hose for outside watering purposes. However, a garden hose can be extremely hazardous because they are left submerged in swimming pools, lay in elevated locations (above the sill cock) watering shrubs, chemical sprayers are attached to hoses for weed-killing, etc.; and hoses are often left laying on the ground which may be contaminated with fertilizer, cess-pools, and garden chemicals.

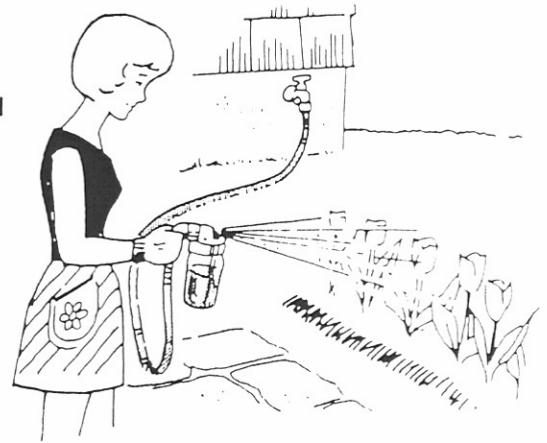

## 8 What protection is required for sill cocks?

A hose bibb vacuum breaker should be installed on every sill cock to isolate garden hose applications thus protecting the potable water supply from contamination.

## 9 Should a hose bibb vacuum breaker be used on frost-free hydrants?

Definitely, providing the device is equipped with means to permit the line to drain after the hydrant is shut-off. A "removable" type hose bibb vacuum breaker could allow the hydrant to be drained, but the possibility exists that users might fail to remove it for draining purposes, thus defeating the benefit of the frost-proof hydrant feature. If the device is of the "Non-Removable" type, be sure it is equipped with means to drain the line to prevent winter freezing.

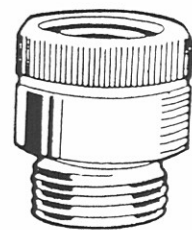

HOSE BIBB VACUUM BREAKER  
No. 8

## 10 Can an atmospheric, anti-siphon vacuum breaker be installed on a hose bibb?

Theoretically yes, but practically no. An anti-siphon vacuum breaker must be elevated above the sill cock to operate properly. This would require elevated piping up to the vacuum breaker and down to the sill cock and is normally not a feasible installation. On the other hand, a hose bibb vacuum breaker can be attached directly to the sill cock, without plumbing changes and at minor cost.

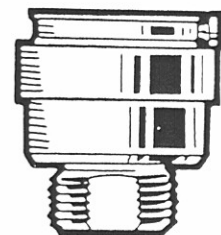

HOSE BIBB VACUUM BREAKER  
FOR FROST-PROOF HYDRANTS  
No. NF8

## 11 What is an atmospheric vacuum breaker?

The most commonly used atmospheric anti-siphon vacuum breakers incorporate an atmospheric vent in combination with a check valve. Its operation depends on a supply of potable water to seal off the atmospheric vent, admitting the water to downstream equipment. If a negative pressure develops in the supply line, the loss of pressure permits the check valve to drop sealing the orifice while at the same time the vent opens admitting air to the system to break the vacuum.

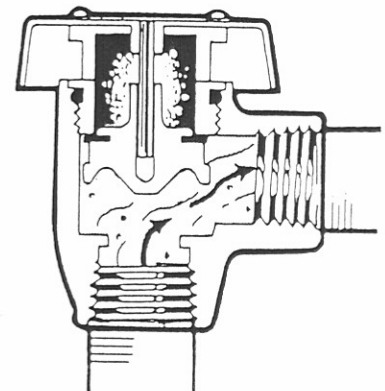

ATMOSPHERIC VACUUM BREAKER  
No. 288A

## 12 Will an anti-siphon vacuum breaker protect against a backpressure backflow condition?

Absolutely not! If there is an increase in the downstream pressure over that of the supply pressure, the check valve would tend to "modulate" thus permitting the backflow of contaminated water to pass through the orifice into the potable water supply line.

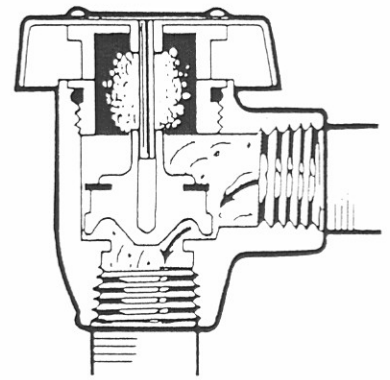

## 13 Can an atmospheric vacuum breaker be used on lawn sprinkler systems?

Yes, if these are properly installed, they will protect the potable water supply. The device shall be installed 6" above the highest sprinkler head and shall have no control valves located downstream from the device.

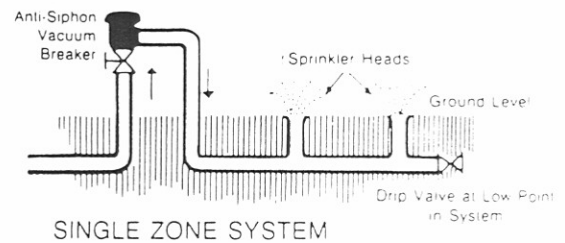

## 14 Can an atmospheric vacuum breaker be used under continuous pressure?

No! Codes do not permit this as the device could become "frozen", and not function under an emergency condition.

## 15 Can a pressure vacuum breaker be used on a multi-zone lawn sprinkler system?

Yes. This type of vacuum breaker can be used under continuous pressure. Therefore, if properly installed, it will protect the potable water supply. The device shall be installed 12" above the highest sprinkler head.

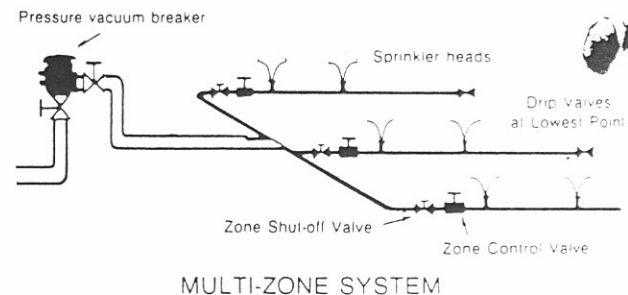

## 16 What is continuous pressure?

This is a term applied to an installation in which the pressure is being supplied continuously to a backflow preventer for periods over 12 hours at a time. Laboratory faucet equipment, for example, is entirely suitable for a non-pressure, atmospheric anti-siphon vacuum breaker because the supply is periodically being turned on and shut off. A vacuum breaker should never be subjected to continuous pressure unless it is of the continuous pressure type and clearly identified for this service.

## 17 Are check valves approved for use on boiler feed lines?

Most jurisdictions require backflow protection on all boiler feed lines. Some will allow a backflow preventer with intermediate vent as minimum protection for residential boilers. A reduced pressure backflow preventer is generally required on commercial and compound boilers.

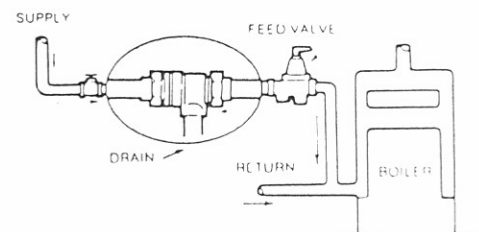



However, low cost, continuous pressure backflow preventers are now available which will perform with maximum protection; thus check valves are not recommended.

## 18 What is the difference between pollution and contamination?

Pollution of the water supply does not constitute an actual health hazard, although the quality of the water is impaired with respect to taste, odor or utility. Contamination of the water supply, however, does constitute an actual health hazard; the consumer being subjected to potentially lethal water borne disease or illness.

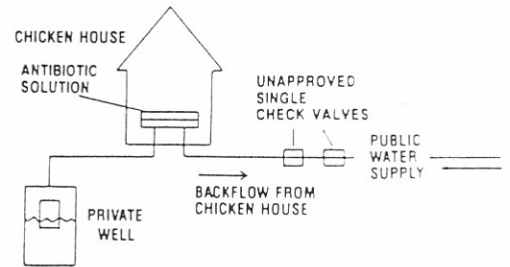

## 19 What recent case would reflect users being exposed to contamination of the water supply?

Chicken House Cross-Connection, Spring 1991. In response to a complaint from a customer on the Casa Water System (Perry County), a staff member of the Division of Engineering found that the water systems had been contaminated by backflow from chicken houses. The water system connected to the chicken houses included two single check valves in series for backflow prevention purposes. The water was being used to administer an antibiotic solution to the chickens.

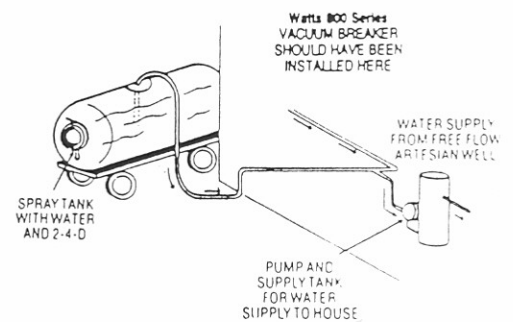

## 20 What other case reflects users being exposed to "contamination" of the water supply?

On or about the week of the 14th of May, 1991, a back-siphonage problem occurred. A local farmer reported the problem on his farm. He was filling a spray tank on his farm with water and 2-4-D. The wind kept blowing the fill hose away from the fill spout so he extended the hose down into the tank. As the tank filled, he went onto other duties. He went to the house for some reason and his wife told him that the water had become salty tasting. He immediately thought of the 2-4-D and went to the tank and it had began siphoning water from the tank. He told his wife not to use any more water. An artesian well, (free flow) which was filling the tank. The artesian well also supplied water to the home through a storage tank and pump system. As the spray tank was filling, the pump in the house came on and created a pull on the well greater than the pressure at the well head. Consequently, as the pump was on, it was also pulling the 2-4-D and water from the spray tank.

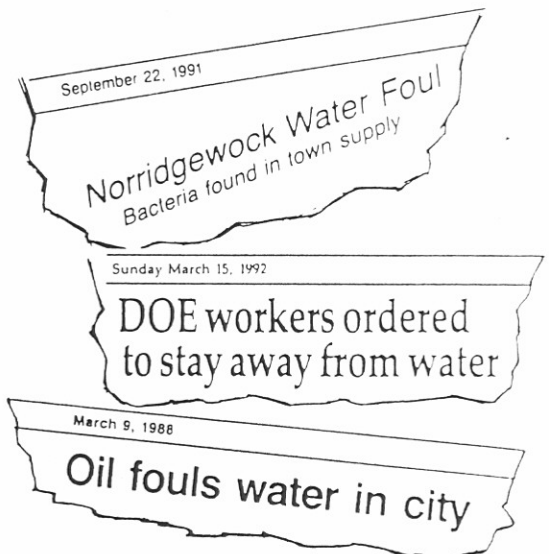

## 21 Are there any other records of recent cases involving unprotected cross connections?

The startling fact is that cross connections continue to occur and there are documented cases involving reverse flow. For other cases, request folder F-SBN.

## 22 What recently reported cases occurred in a plant?

In addition to the case described in "No. 19", there are other reports but because of the possibility of litigation for pending cases, information can be difficult to obtain. However, in San Francisco, an industrial plant had a submerged water inlet supplying a lye vat. Immediately adjacent to this installation was the employee's shower room. Officials fortunately discovered the cross connection, but were alarmed that employees could potentially be bathing in water contaminated with lye from the vats.

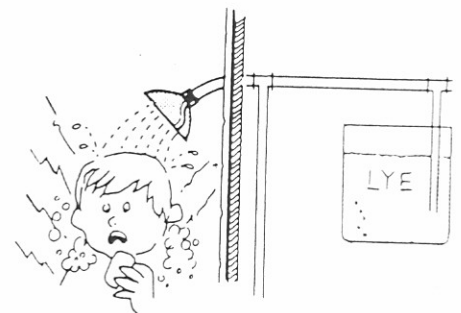

## 23. What case was reported involving a school?

Most people are familiar with the details of the Holy Cross Football Teams' "hepatitis" incident, which was later determined to be caused by a backflow of contaminated water. It took close to nine months for officials to determine that a severe fire in nearby Worcester lowered the pressure in the football field area to the point where a back pressure backflow condition was created allowing contaminants from a sunken hose bibb pit to backflow into the field house drinking bubbler.



## 24. What case was reported involving a commercial building?

Much to the surprise of the customers of a bank in Atlanta, Georgia they saw yellow water flowing from drinking fountains and green ice rolling out of cafeteria dispensing machines.

It was later reported that a pump, used for the air conditioning system, burned out; and a maintenance man, unaware of the danger, connected the system to another pump used for potable water. The result caused large doses of bichromate of soda to be forced into the potable water supply, causing the dramatic appearance of yellow water and colored ice cubes.



## 25. Are there any cases involving outside processing activities?

Yes, a case occurred in a gravel pit operation in Illinois. A pump was used in the processing operation supplying 100 lbs. pressure. Contaminated water was forced back through an unprotected "prime line" overcoming the city water pressure of 45 lbs. The contaminated water entered the city main and was channeled into a nearby bottling plant. This probably would have gone undetected except that personnel in the bottling plant noticed that the water was not only dirty but was warm. City officials were immediately called which led to the discovery of the reverse flow from the gravel pit operation.

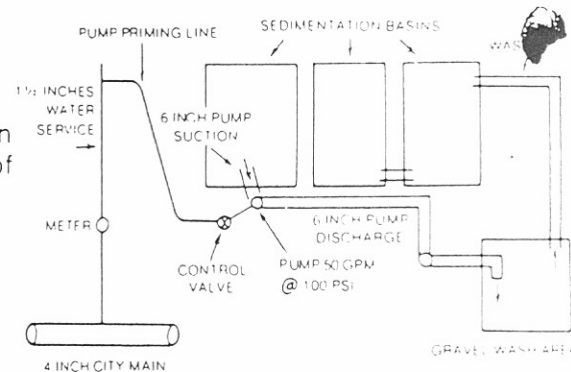

## 26. What other typical cases have been reported?

**Unwanted Guests (Residents find parasites in tap water) Oct. 1991.** Parasitological worms were found in the water at two homes after a malfunctioning lawn sprinkler coupled with a water main break sucked the nematodes into the water system.

The nematodes first showed up the evening of Oct. 1 after the backflow prevention system on the privately owned underground sprinkler malfunctioned. When the water pressure dropped, the vacuum in the system sucked some water from the sprinkler into the city water.

A homeowner found the worms swimming around in his bathtub when he started filling the tub for his child. He said he was appalled to find the critters, as well as rust and other debris in his water. "The only reason I noticed it is because I have children and was giving my kid a bath. If you have a screen on your faucet or you were taking a shower, you wouldn't see it."

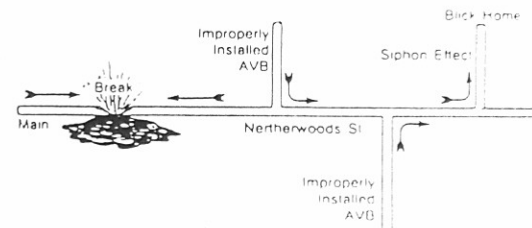



The contractor who installed the sprinkler system didn't pull a city permit and used a "cheap" atmospheric vacuum breaker. When it malfunctioned, which was at the time of the water main break, the nematodes were pulled right in.

In Utah, a doctor reported two gold fish flowing into his bath tub. Earlier in the day he had been filling his gold fish pool with a garden hose when a back-siphonage condition developed resulting in the late emergence of the gold fish into the bath tub.

What is significant, however, is the number of recent cases that are not reported. The number of unprotected cross connections in existence are potential disasters which can occur any time unless adequate protective devices are installed.

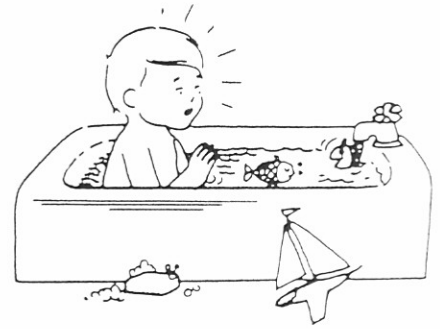

## 27 What is meant by "Degree of Hazard"?

The degree of hazard is a commonly used phrase utilized in cross connection programs and is simply a determination on whether the substance in the non-potable system is toxic (health hazard) or non-toxic (non-health hazard).



Health Hazard



Non-Health Hazard

## 28 What is the difference between a toxic and a non-toxic substance?

Toxic substance is any liquid, solid or gas, which when introduced into the water supply creates, or may create, a danger to health and well-being of the consumer. An example is treated boiler water. A non-toxic substance is any substance that may create a non-health hazard, is a nuisance or is aesthetically objectionable. For example, food stuff, such as sugar, soda pop, etc. Therefore, you must select the proper device according to the type of connection and degree of hazard. There are five basic products that can be used to correct cross connection.



## 29 What are the five basic products used for protection of cross connections?

The five basic products are:

1. Air Gap
2. Atmospheric Vacuum Breakers - which also includes hose connection vacuum breakers
3. Pressure Vacuum Breakers - which also includes backflow preventer with intermediate atmospheric vent for 1/2" and 3/4" lines.
4. Double Check Valve Assembly
5. Reduced Pressure Principle Backflow Preventers

## 30 What is an Air Gap?

Air Gap is the physical separation of the potable and non-potable system by an air space. The vertical distance between

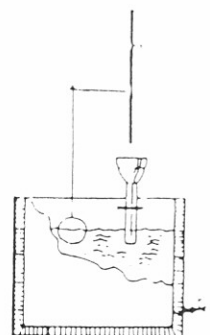
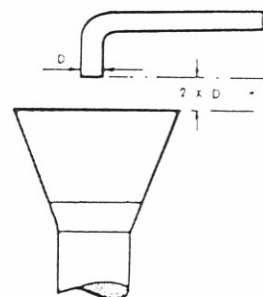

the supply pipe and the flood level rim should be two times the diameter of the supply pipe, but never less than 1". The air gap can be used on a direct or inlet connection and for all toxic substances.

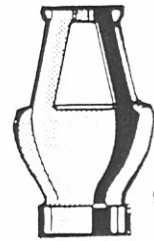

909AG Series

### 31 Where is an Atmospheric Vacuum Breaker used?

Atmospheric Vacuum Breakers may be used only on connections to a non-potable system where the vacuum breaker is never subjected to back-pressure and is installed on the discharge side of the last control valve. It must be installed above the usage point. It cannot be used under continuous pressure. (Also see No.11)

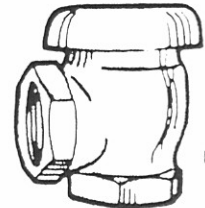

No. 288A

### 32 Where is a Hose Bibb Vacuum Breaker used?

Hose Bibb Vacuum Breakers are small inexpensive devices with hose connections which are simply attached to sill cocks, and threaded faucets or wherever there is a possibility of a hose being attached which could be introduced to a contaminant. However, like the Atmospheric Vacuum Breaker they should not be used under continuous pressure.

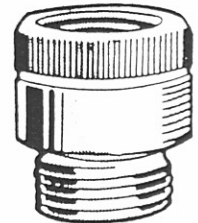

No. 8

### 33 Where is a Pressure Vacuum Breaker used?

Pressure Vacuum Breakers may be used as protection for connections to all types of non-potable systems where the vacuum breakers are not subject to back-pressure. These units may be used under continuous supply pressure. They must be installed above the usage point.

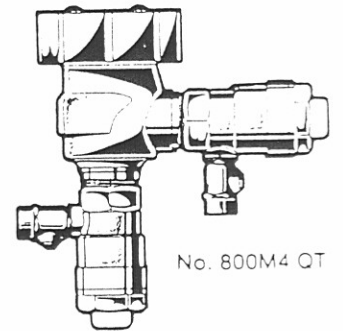

No. 800M4 QT

### 34 Where is a Backflow Preventer with Intermediate Atmospheric vent used?

These devices are made for 1/2" and 3/4" lines and may be used as an alternate equal for pressure vacuum breakers. In addition, however, they provide the added advantage of providing protection against back-pressure.

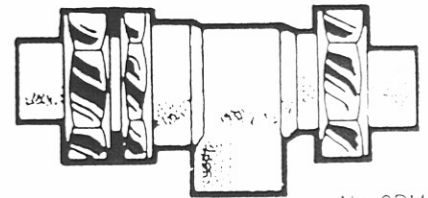

No. 90M3/M2

### 35 Where is a Double Check Valve Assembly used?

A double check valve assembly may be used as protection of all direct connections through which foreign material might enter the potable system in concentration which would constitute a nuisance or be aesthetically objectionable, such as air, steam, food, or other material which does not constitute a health hazard.

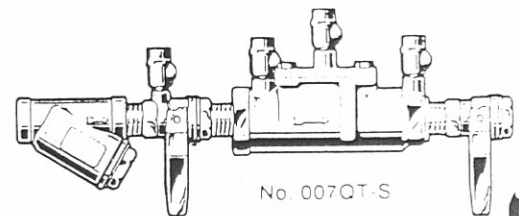

No. 007QT-S

### 36 Where is a Reduced Pressure Principle Backflow Preventer used?

Reduced Pressure Zone Assemblies may be used on all direct connections which may be subject to backpressure or back-siphonage, and where there is the possibility of contamination by the material that does constitute a potential health hazard.

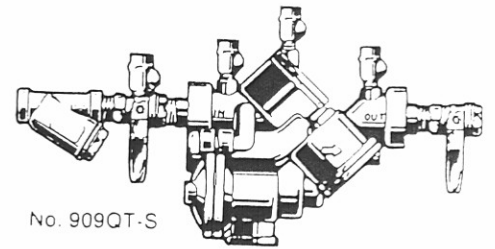

No. 909QT-S

### 37 What are typical applications for an Air Gap?

Because today's complex plumbing systems normally require continuous pressure, air gap applications are actually in the minority. It should be remembered, however, that whenever a piping terminates a suitable distance above a contaminant, this itself is actually an air gap. Air Gaps are frequently used on industrial processing application, but care should be taken that subsequent alterations are not made to the piping which would result in a direct connection.

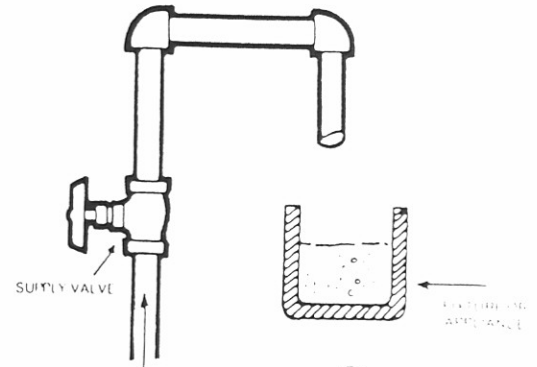

### 38 What are typical applications for Atmospheric Vacuum Breakers?

Atmospheric Vacuum Breakers can be used on most inlet type water connections which are not subject to back-pressure such as low inlet feeds to receptacles containing toxic and non-toxic substances, valve outlet or fixture with hose attachments, lawn-sprinkler systems and commercial dishwashers.

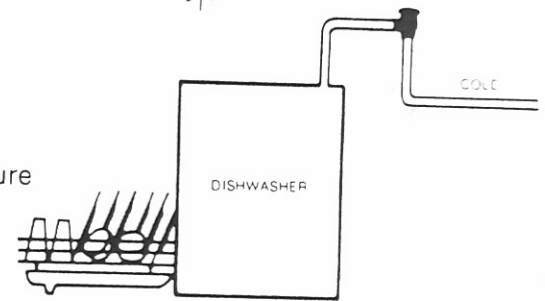

### 39 What are typical applications for Hose Bibb Vacuum Breakers?

Hose Bibb Vacuum Breakers are popularly used on sill cocks, service sinks and any threaded pipe to which a hose may potentially be attached.

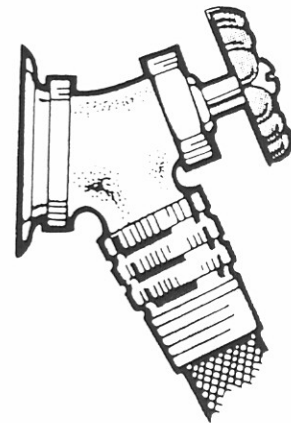

### 40 What are typical applications for Pressure Vacuum Breakers?

These applications should be similar to the Atmospheric Vacuum Breaker with the exception that these may be used under continuous pressure. However, they should not be subject to back-pressure.

### 41 What are typical applications of Backflow Preventer with Intermediate Vent?

For 1/2" and 3/4" lines these devices are popularly used on boiler feed water supply lines, cattle drinking fountains, trailer park water supply connections and other similar low-flow applications. They will protect against both back-siphonage and back-pressure and can be used under continuous pressure.

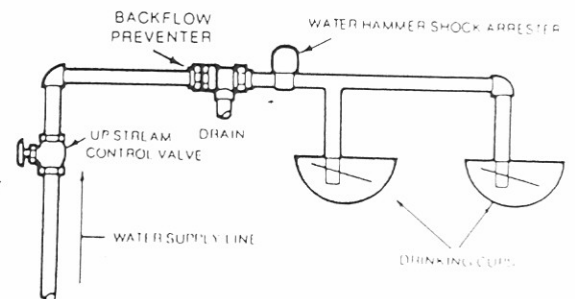

## 42 What are typical applications for Double Check Valve Assemblies?

Briefly, Double Check Valve Assemblies may be used where the degree of hazard is low, meaning that the non-potable source is polluted rather than contaminated. The degree of hazard is oftentimes determined by local Inspection Departments and, therefore, such departments should be questioned in order to comply with local regulations.

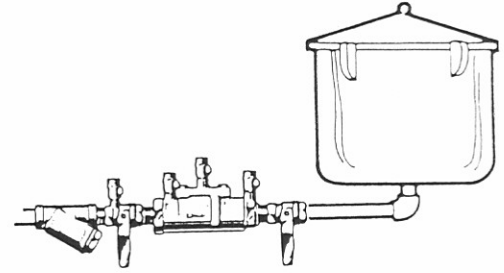

## 43 What are typical applications for Reduced Pressure Principle Backflow Preventers?

This type should be used whenever the non-potable source is more of a contaminant than a pollutant. Basically, they are applied as main line protection to protect the municipal water supply, but should also be used on branch line applications where non-potable fluid would constitute a health hazard, such as boiler feed lines, commercial garbage disposal systems, industrial boilers, etc.

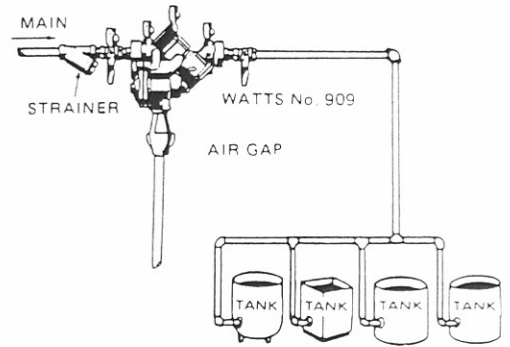

## 44 Are there any regulations in OSHA regarding cross connections?

Yes, OSHA requires that no cross connection be allowed in an installation unless it is properly protected with an approved backflow preventer. These requirements are also covered in B.O.C.A., Southern Std. Building Code, Uniform Plumbing Code and City, State and Federal Regulations.

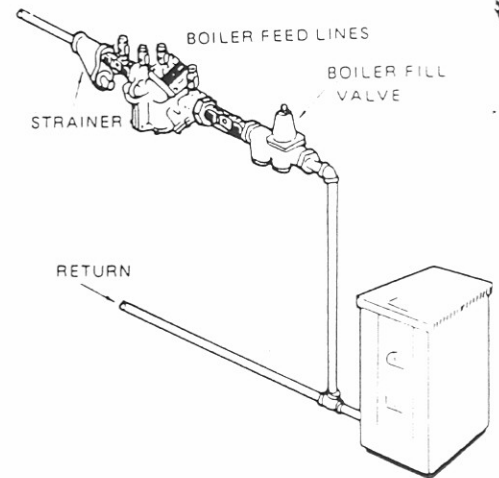

## 45 What Standards are available governing the manufacture of backflow prevention devices?

Table on Page 12 provides a summary of the various standards available relating to specific types of backflow preventers.

## 46 What is the benefit of a strainer preceding a backflow preventer?

A strainer will protect the check valves of a backflow preventer from fouling due to foreign matter and debris which may be flowing through the line. This not only protects the valve but eliminates nuisance fouling and subsequent maintenance and shutdown. The use of a strainer with a water pressure reducing valve has been an accepted practice for years. The amount of pressure drop attributed to the strainer is negligible and is far outweighed by the advantages provided by the strainer.



## 47 What would cause a reduced pressure principle backflow preventer to leak?

Leakage from a backflow preventer is normally attributed to foreign matter lodging on the seating area of either the first or second check valve. Most times this can be corrected by simply flushing the valve which will dislodge any loose particles. It is, therefore, most important on new installations that the piping be thoroughly flushed before installing the unit. It should be remembered, however, that spillage does provide a "warning signal" that the valve is in need of maintenance.

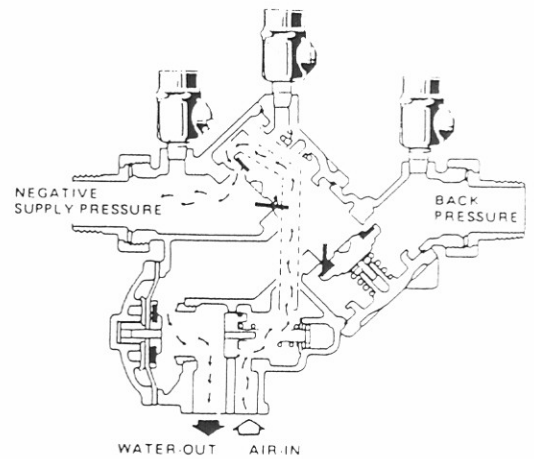

## 48 Is periodic testing required for reduced pressure principle backflow preventers?

Yes, and this is to ensure that the valve is working properly and is a requirement of many states and cross connection control programs. Test cocks are provided on the valve for this purpose and manufacturers are required to furnish field testing information.

## 49 Should a backflow preventer be installed in the water supply line to each residence?



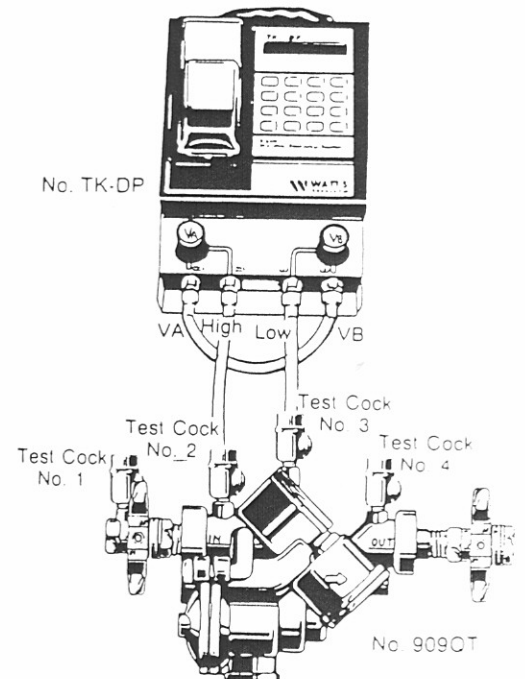

Because of the growing number of serious residential backflow cases, many water purveyors are now requiring the installation of approved dual check valve backflow preventers at residential water meters. They are also educating the public concerning cross connections and the danger of backflow into the local water supply. Since water purveyors cannot possibly be responsible for or monitor the use of water within a residence, the requirements for these cross connection control programs are increasing throughout the country.

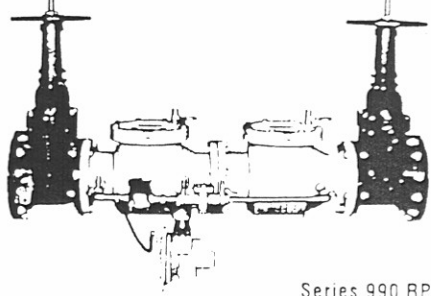
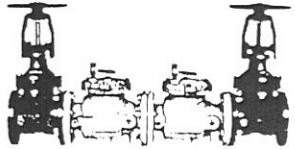
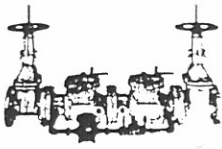
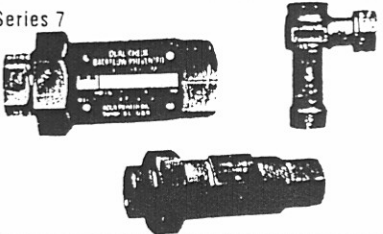

## 50 What is a cross connection control program?

This is a combined cooperative effort between plumbing and health officials, water works companies, property owners and certified testers to establish and administer guidelines for controlling cross connections and implementing means to ensure their enforcement so that the public potable water supply will be protected both in the city main and within buildings. The elements of a program define the type of protection required and responsibility for the administration and enforcement. Other elements ensure continuing education programs.

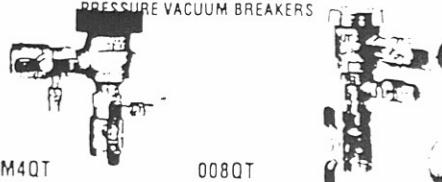

APPLICABLE STANDARDS	USC Approvals*		AVAILABLE PRODUCT SIZES	PAGE NO.	
	Series	Size (Inches)			
ASSE Std 1013, AWWA C511-92, IAPMO PS31, CSA B64.4	009	1/2 - 3"	1/2 - 3	8	<p>REDUCED PRESSURE DETECTOR ASSEMBLIES, REDUCED PRESSURE ZONE BACKFLOW PREVENTERS</p>  <p>Series 990 RPDA</p>
ASSE Std 1013, AWWA C511-92, CSA B64.4, IAPMO PS31	909	3/4 - 10"	3/4 - 10	6, 7	
ASSE Std 1047, CSA B64.4	909RPDA	3 - 10"	3 - 10	11	
ASSE Std 1013, AWWA C511-92, IAPMO PS 31	990	4 & 8"	4 - 8	9	
ASSE Std 1047, CSA B64.4	990RPDA	4 & 8"	4 - 8	10	
ASSE Std 1013, AWWA C511-92, CSA B64.4	992	4 & 10"	4 - 10	†	
ASSE Std 1015, AWWA C510-92, CSA B64.5, APMO PS31	007	1/2 - 3"	1/2 - 3	12	<p>DOUBLE CHECK VALVE ASSEMBLIES</p>  <p>Series 770</p>
ASSE Std 1015, AWWA C510-92, CSA B64.5	709	2-1/2 - 10"	2-1/2 - 10	13	
ASSE Std 1015, AWWA C510-92, CSA B64.5	770	4 & 8"	4 - 8	14	
ASSE Std 1015, AWWA C510-92, CSA B64.5	772	4 & 10"	4 - 10	††	
ANSI/ASSE Std. 1048, CSA B64.5	007DCDA	2 1/2 - 3	2 1/2 - 3	12	<p>DOUBLE CHECK DETECTOR ASSEMBLIES</p>  <p>Series 770DCDA</p>
ANSI/ASSE Std 1048, CSA B64.5	709DCDA	3 - 10"	3 - 10	16	
ANSI/ASSE Std 1048, CSA B64.5	770DCDA	4 & 8"	4 - 8	15	
ANSI/ASSE Std. 1048, CSA B64.6	772DCDA	4 & 10"	4 - 10	†††	
ANSI/ASSE Std. 1024, CSA B64.6	7	—	1/2 - 1-1/4	18, 19	<p>DUAL CHECK VALVE BACKFLOW PREVENTERS</p> <p>Series 7</p> 
ANSI/ASSE Std 1024, CSA B64.6	7B	—	3/4	18	
ANSI/ASSE Std 1024, CSA B64.6	A7	—	5/8, 3/4	18	
ANSI/ASSE Std 1024, CSA B64.6	07S	—	1	19	
ASSE Std 1024, CSA B64.6	7C	—	3/8	20	
ANSI/ASSE Std 1012, CSA B64.8	9DM3/M2, 911	—	1/2 - 3/4	17	
CSA Std B64.8	9B0	—	3/8" FCT 1/4, 3/8 NPTM	21	
ASSE Std 1035, CSA B64.8	NLF9	—	3/8	20	
ASSE Std 1035, CSA B64.8	N9	—	1/4, 3/8	20	
ANSI/ASSE Std 1001, CSA B64.1.1	288A	3/4 - 3"	1/4 - 3	25	<p>ATMOSPHERIC BREAKERS</p>  <p>Series 288A</p>
ANSI/ASSE Std 1001, CSA B64.1.1	N388	—	1/4 - 3/8	25	
ANSI/ASSE Std 1001, CSA B64.1	188A	—	3/4 - 2	25	
ANSI/ASSE 1020, CSA B64.1.2	800MQT	1/2, 3/4"	1/2, 3/4	22	<p>PRESSURE VACUUM BREAKERS</p>  <p>800MQT      008QT</p>
ANSI/ASSE 1020, CSA B64.1.2	800M4QT	1/2 - 2"	1/2 - 2"	22, 23	
ASSE 1056	008QT	—	3/8 & 1/2	24	
ASSE Std 1011, CSA B64.2	S8C, 8, NFB	—	3/8, 1/2, 3/4 HT	26, 27	
ASSE Std 1019 CSA B64.3	FHB-1	—	1/2	27	<p>HOSE CONNECTOR VACUUM BREAKERS</p>  <p>Series 8</p>

\*For latest approval status, refer to Engineering Specification Sheets for approved sizes and product numbers. †See ES-992, †† See ES-772 †††. See ES-772DCDA



<b>INDEX OF STANDARD DRAWINGS</b>			
<b>DRAWING NO.</b>		<b>DRAWING DESCRIPTION</b>	<b>REVISION DATE</b>
SET		COMPLETE SET	32.7 MB
<b>GENERAL STANDARDS</b>			
GS		CONTAINES GENERAL, WATER LINE, SANITARY, DRAINAGE, GENERAL PLAN NOTES, ROADWAY, AND STREET DESIGN STANDARDS.	2.92 MB
<b>ADDENDUMS</b>			
AD-A		"A" CITY WATER DEPARTMENT RULES & REGULATIONS	1.52MB
AD-B		"B" WATER VALVE OPERATION	.3MB
AD-C		"C" BACKFLOW PREVENTION PROGRAM	12.7MB
<b>CITY STREET - TYPICAL SECTION</b>			
SD-10		RESIDENTIAL / RIGID PAVEMENT	Nov-97
SD-11		RESIDENTIAL / FLEXIBLE PAVEMENT	Nov-97
SD-12		COMMERCIAL - HEAVY TRUCK / RIGID PAVEMENT	Nov-97
SD-13		COMMERCIAL - HEAVY TRUCK / FLEXIBLE PAVEMENT	Nov-97
SD-14		CITY LANES, DRIVER, & ALLEYS / FLEXIBLE PAVEMENT	Nov-97
SD-16		STANDARD CUL-DE-SAC DETAILS	Dec-93
SD-17		DRIVEWAY TYPICAL DETAILS	Aug-93
SD-18		DRIVEWAY - STREET TRANSITIONAL DETAIL	May-12
SD-20		CONCRETE CURBS AND COMBINED CURB & GUTIER	Feb-99
SD-21		4" PIPE UNDERDRAIN DETAILS	Nov-97
SD-22		THRU CURB ROOF DRAIN DETAILS	Nov-00
SD-23		CONCRETE SIDEWALK DETAILS	Oct-99
SD-24		HANDICAP ACCESS CURB RAMP (ODOT BP-7.1)	Jan-00
SD-25A		CONCRETE CURB PAVEMENT REPLACEMENT DETAILS	9-May
SD-100		THRUST BLOCKING DETAILS - HORIZONTAL BENDS	Jan-94
SD-101		THRUST BLOCKING DETAILS - VERTICAL BENDS	Jun-92
SD-106		GRANULAR BACKFILL DETAIL FOR TRENCH	Mar-13
SD-107		CONTROLLED DENSITY FILL DETAIL FOR TRENCH	Apr-93
<b>PAVEMENT REPLACEMENT</b>			
SD-109		ASPHALT SURFACE ON AGGREGATE BASE	Mar-13
SD-110		ASPHALT SURFACE ON CONCRETE BASE	Sep-95
SD-115		CONCRETE PAVEMENT	Jun-92
<b>PIPE BEDDING / BACKFILL &amp; TRENCH DETAILS</b>			
SD-116S		FOR ALL RIGID SEWER PIPE	Feb-99
SD-116W		FOR ALL RIGID WATER PIPE	Mar-13
SD-117		FOR ALL FLEXIBLE SEWER & WATER PIPE	Feb-96
SD-118		TYPICAL TRENCH DETAIL	Feb-96
<b>MANHOLE AND CATCH BASIN DETAILS</b>			
SD-119		PRECAST CONCRETE MANHOLE DETAIL	Feb-96
SD-120		CAST IN PLACE CONCRETE MANHOLE DETAIL	Jan-94
SD-121		PRECAST MONOLITHIC CONCRETE MANHOLE DETAIL	Jan-94
SD-122		DROP MANHOLE DETAIL WITH PRECAST MONOLITHIC BASE	Jan-94
SD-123		PRECAST MONOLITHIC BASE DETAIL FOR DROP MANHOLES	Jan-94
SD-124		DROP MANHOLE DETAIL WITH CAST IN PLACE BASE	Jan-94
SD-125		INSIDE DROP MANHOLE DETAIL	Jan-94
SD-126		PRECAST SHALLOW MANHOLE TOP	Jan-94
SD-127		DROP MANHOLE DETAIL WITH PRECAST BASE & HOLES	Nov-92
SD-128		INSIDE DROP MANHOLE DETAIL	Jun-92
SD-130		CATCH BASIN STANDARDS	Mar-99
<b>WATERLINE DETAILS</b>			
SD-132		TYPICAL VALVE & VALVE BOX SETIING	Feb-15
SD-133		FIRE HYDRANT ASSEMBLY WITH VALVE & VALVE BOX	Feb-15
SD-139		TYPICAL SERVICE LINE AND SERVICE STOP SETIING	Mar-13
SD-140		TYPICAL END OF WATERLINE DETAIL	May-12
SD-150		BLOW-OFF ASSEMBLY -REMOVED	Nov-2021

CITY OF NEW PHILADELPHIA  
 CITY STREET-TYPICAL SECTION  
 RESIDENTIAL / RIGID PAVEMENT

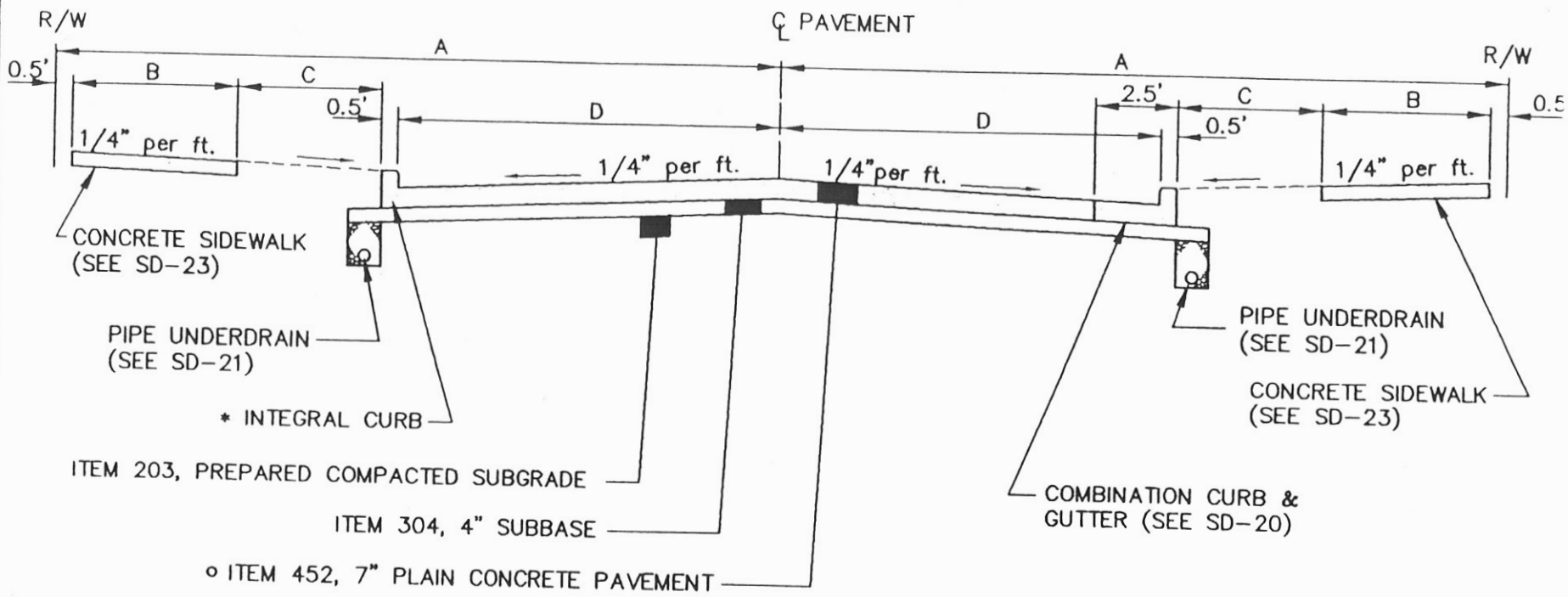

- \* ALTERNATE CURB TYPE WITHOUT GUTTER (SEE SD-20)
- o ITEM 451, 6" REINFORCED CONCRETE PAVEMENT MAY BE USED AS AN ALTERNATE.

R/W WIDTH	A	B	C	D
40'	20.0'	4.0'	3.0'	12.0'
50'	25.0'	5.0'	4.0'	15.0'
60'	30.0'	5.0'	6.0'	18.0'

FOR ADDITIONAL SPECIFICATIONS, SEE CHAPTER 909 OF CITY CODIFIED ORDINANCE.  
 ITEM NUMBERS, MATERIALS AND METHODS OF INSTALLATION IN ACCORDANCE WITH THE  
 LATEST EDITION OF O.D.O.T. "CONSTRUCTION AND MATERIAL SPECIFICATIONS" BOOK.

STANDARD CONSTRUCTION DRAWING NO.  
 SD-10  
 REV. 11-97



**CITY OF NEW PHILADELPHIA**

**CITY STREET-TYPICAL SECTION  
RESIDENTIAL / FLEXIBLE PAVEMENT**

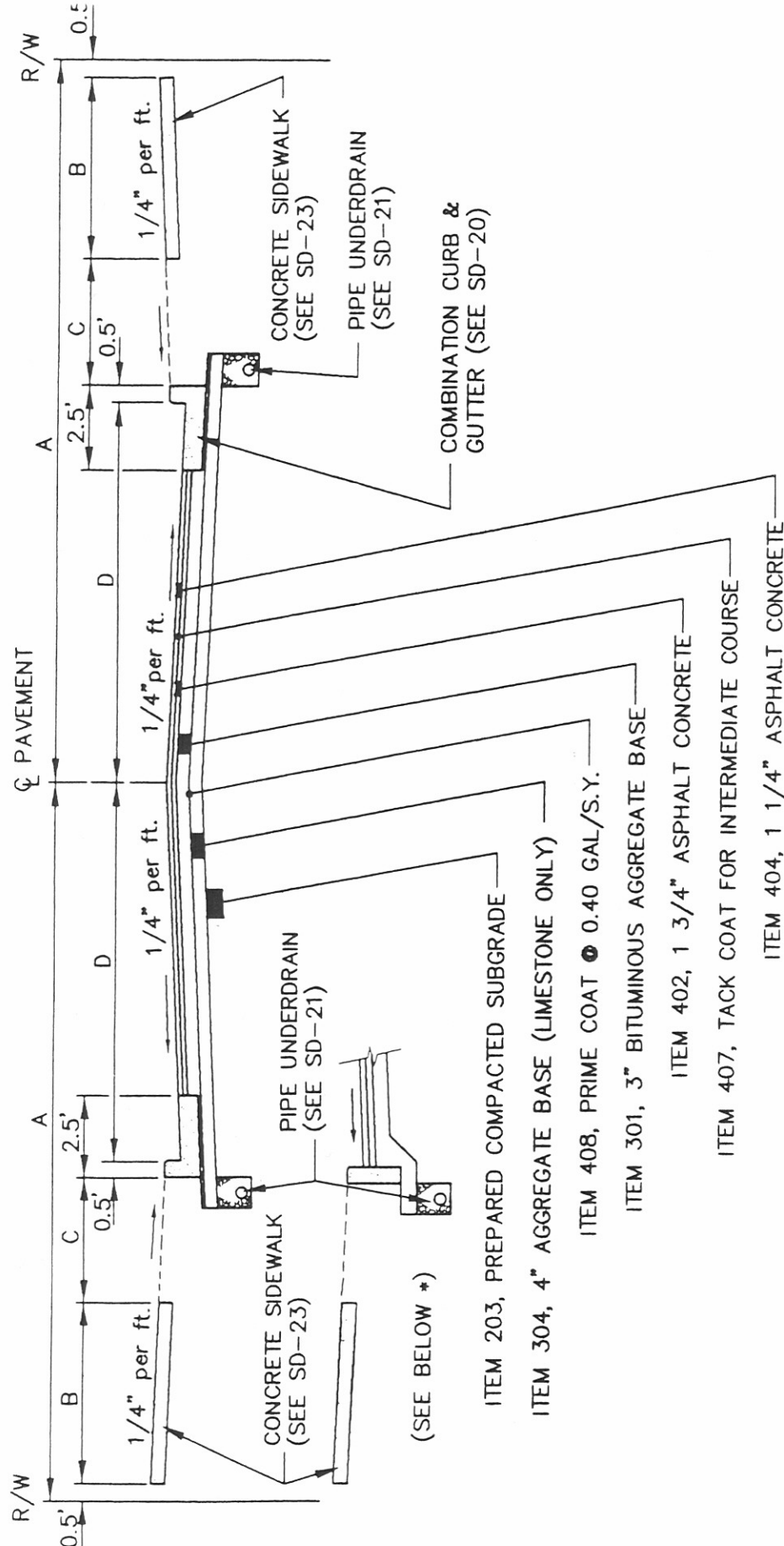

\* ALTERNATE CURB TYPE 6 WITHOUT GUTTER (SEE SD-20)

R/W WIDTH	A	B	C	D
40'	20.0'	4.0'	3.0'	12.0'
50'	25.0'	5.0'	4.0'	15.0'
60'	30.0'	5.0'	6.0'	18.0'

FOR ADDITIONAL SPECIFICATIONS, SEE CHAPTER 909 OF CITY CODIFIED ORDINANCE.  
 ITEM NUMBERS, MATERIALS AND METHODS OF INSTALLATION IN ACCORDANCE WITH THE  
 LATEST EDITION OF O.D.O.T. "CONSTRUCTION AND MATERIAL SPECIFICATIONS" BOOK.

STANDARD  
 CONSTRUCTION  
 DRAWING NO.  
**SD-11**  
 REV. 11-97

CITY OF NEW PHILADELPHIA  
 CITY STREET-TYPICAL SECTION  
 COMMERCIAL-HEAVY TRUCK / RIGID PAVEMENT

STANDARD  
 CONSTRUCTION  
 DRAWING NO.  
**SD-12**  
 REV. 11-97

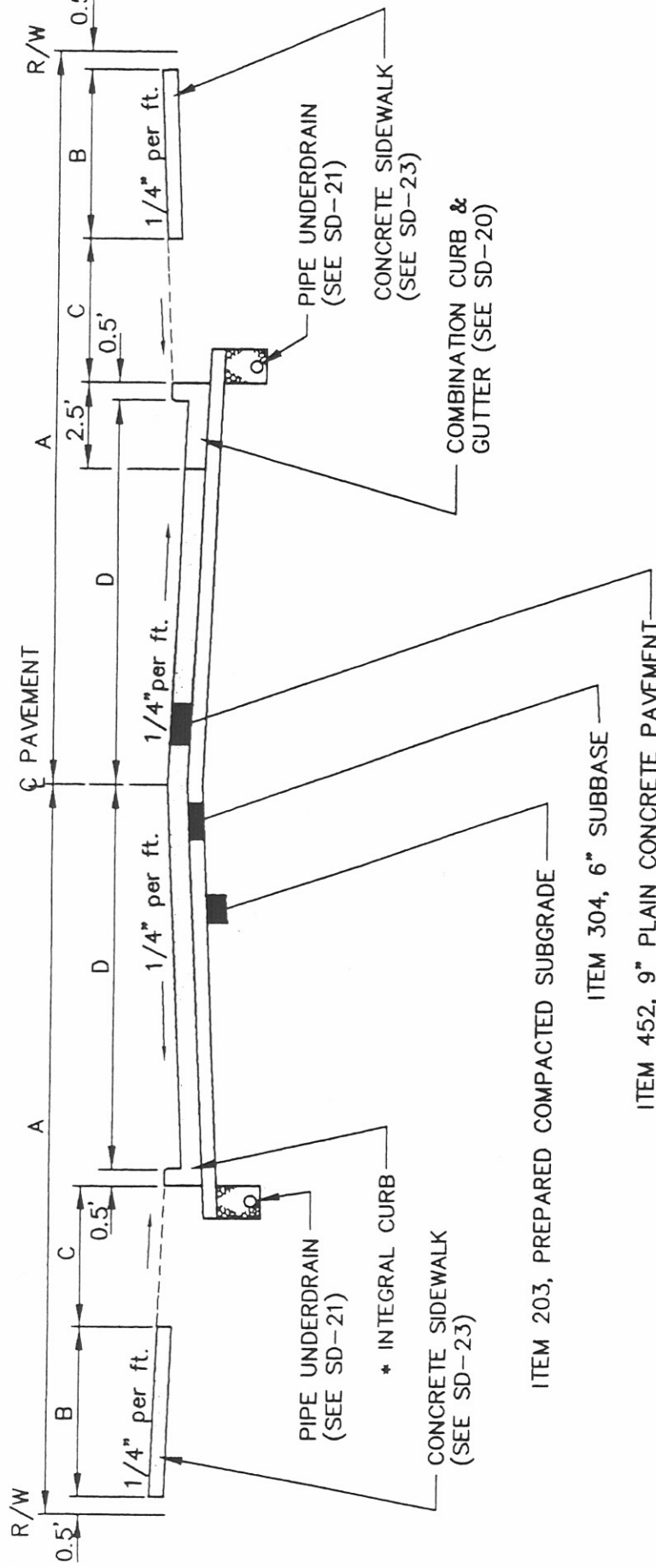

\* ALTERNATE CURB TYPE 2A WITHOUT GUTTER (SEE SD-20)

R/W WIDTH	A	B	C	D
40'	20.0'	4.0'	3.0'	12.0'
50'	25.0'	5.0'	4.0'	15.0'
60'	30.0'	5.0'	6.0'	18.0'

FOR ADDITIONAL SPECIFICATIONS, SEE CHAPTER 909 OF CITY CODIFIED ORDINANCE.  
 ITEM NUMBERS, MATERIALS AND METHODS OF INSTALLATION IN ACCORDANCE WITH THE  
 LATEST EDITION OF O.D.O.T. "CONSTRUCTION AND MATERIAL SPECIFICATIONS" BOOK.

**CITY OF NEW PHILADELPHIA**  
**CITY STREET-TYPICAL SECTION**  
**COMMERCIAL-HEAVY TRUCK / FLEXIBLE PAVEMENT**

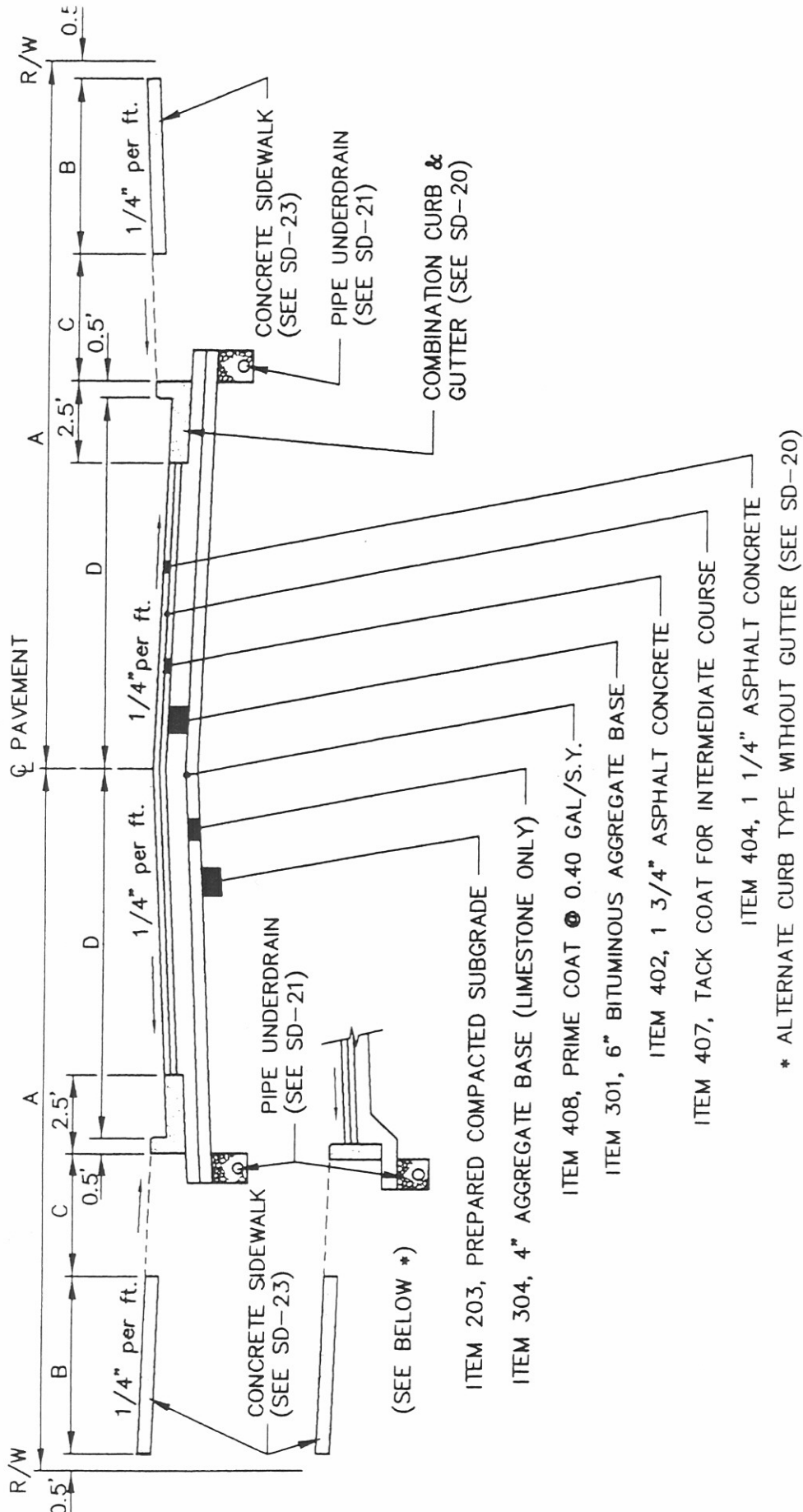

R/W WIDTH	A	B	C	D
40'	20.0'	4.0'	3.0'	12.0'
50'	25.0'	5.0'	4.0'	15.0'
60'	30.0'	5.0'	6.0'	18.0'

\* ALTERNATE CURB TYPE WITHOUT GUTTER (SEE SD-20)

FOR ADDITIONAL SPECIFICATIONS, SEE CHAPTER 909 OF CITY CODIFIED ORDINANCE.  
 ITEM NUMBERS, MATERIALS AND METHODS OF INSTALLATION IN ACCORDANCE WITH THE  
 LATEST EDITION OF O.D.O.T. "CONSTRUCTION AND MATERIAL SPECIFICATIONS" BOOK.

STANDARD  
 CONSTRUCTION  
 DRAWING NO.  
**SD-13**  
 REV. 11-97

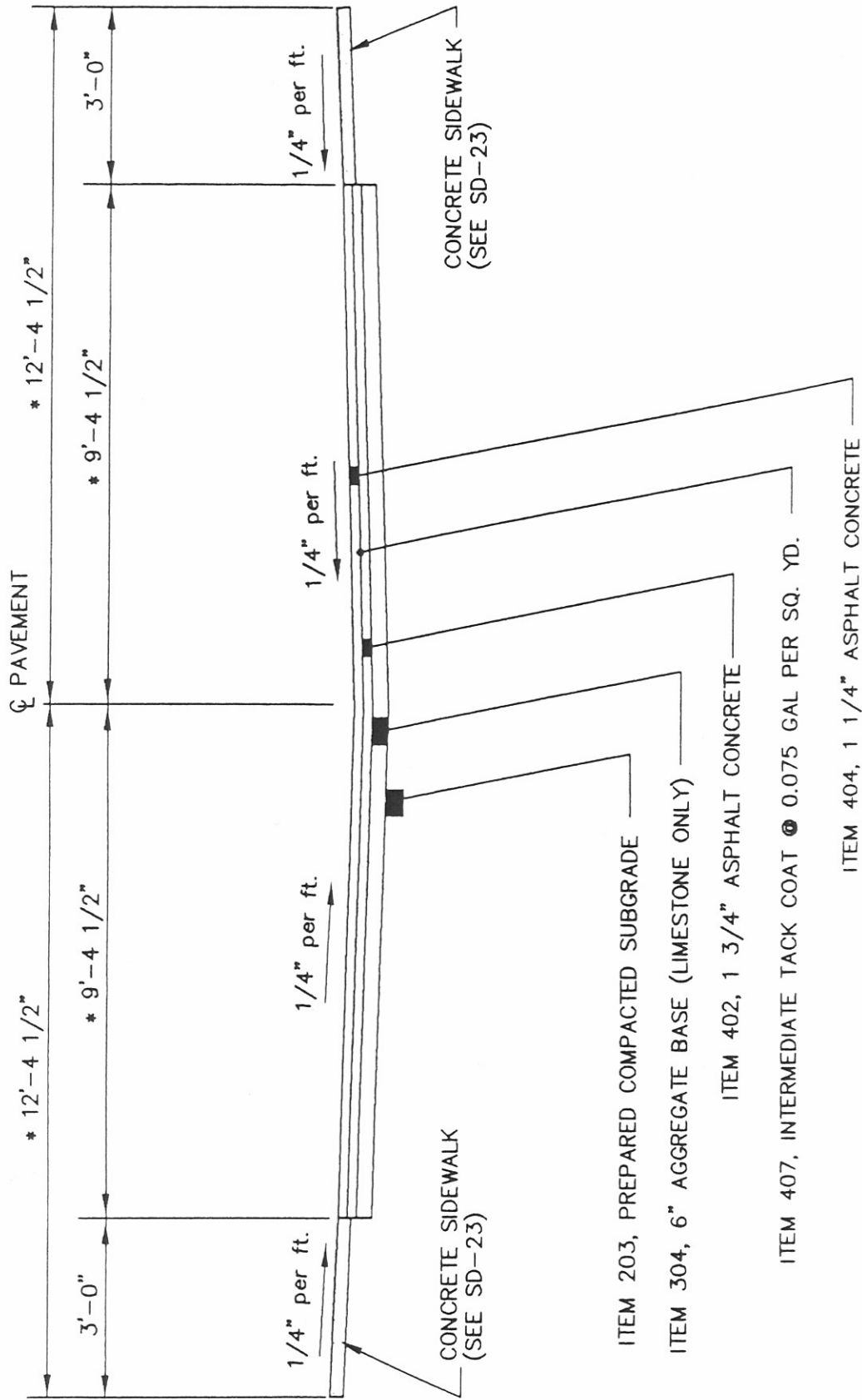

\* DIMENSIONS SHOWN ARE FOR LANES AND DRIVES, CHECK WITH CITY FOR ALLEY DIMENSIONS.  
 ITEM NUMBERS, MATERIALS AND METHODS OF INSTALLATION IN ACCORDANCE WITH THE  
 LATEST EDITION OF O.D.O.T. "CONSTRUCTION AND MATERIAL SPECIFICATIONS" BOOK.

CITY OF NEW PHILADELPHIA		STANDARD CONSTRUCTION DRAWING NO. <b>SD-14</b> REV. 11-97
TYPICAL SECTION / FLEXIBLE PAVEMENT CITY LANES, DRIVES, AND ALLEYS		

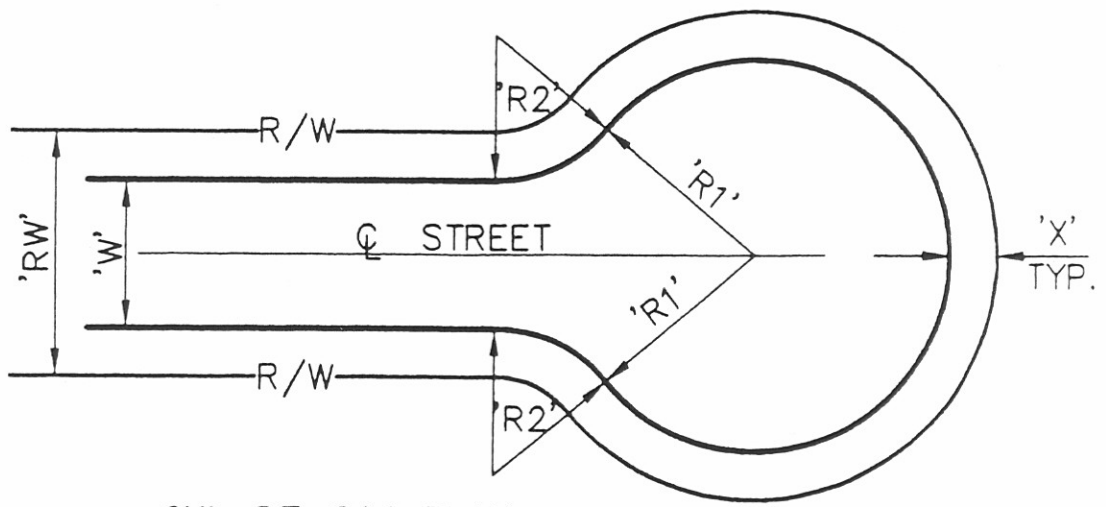

**CUL-DE-SAC PLAN**  
(HAMMER HEAD STYLE)

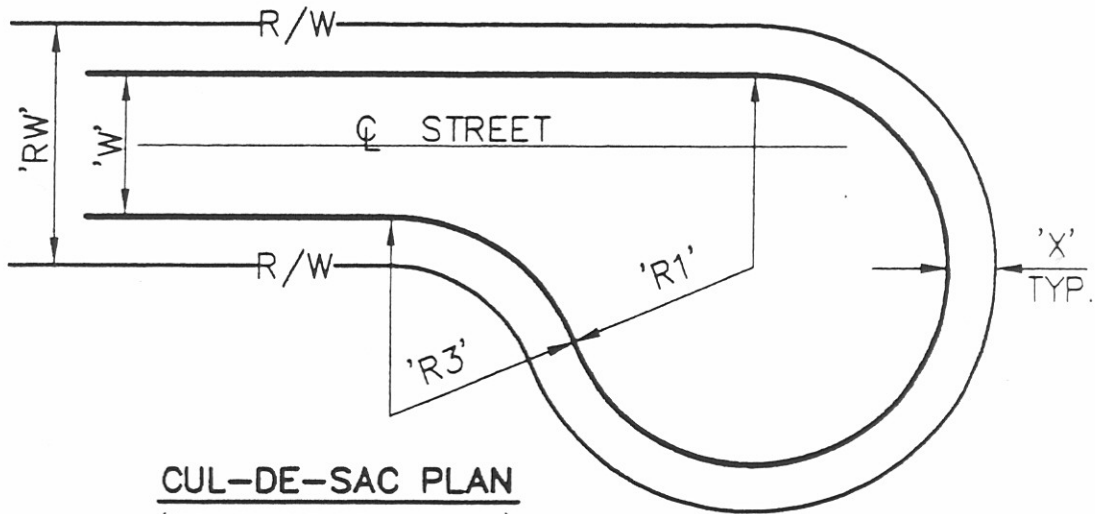

**CUL-DE-SAC PLAN**  
(TEAR DROP STYLE)

NOTE: TEAR DROP CUL-DE-SAC MAY BE CON-  
STRUCTED OPPOSITE HAND IF DESIRED.

**TABLE OF DIMENSIONS**

'RW'	PAV'T WIDTH 'W'	RADIUS 'R1'	RADIUS 'R2'	RADIUS 'R3'	'W/2'	'X'
40'	24'	37'	30'	30'	12'	8'
50'	30'	40'	30'	40'	15'	10'
60'	36'	43'	30'	50'	18'	12'

<b>CITY OF NEW PHILADELPHIA</b>	STANDARD CONSTRUCTION DRAWING NO. <b>SD-16</b> REV. 12-93
<b>STANDARD CUL-DE-SAC DETAILS</b>	

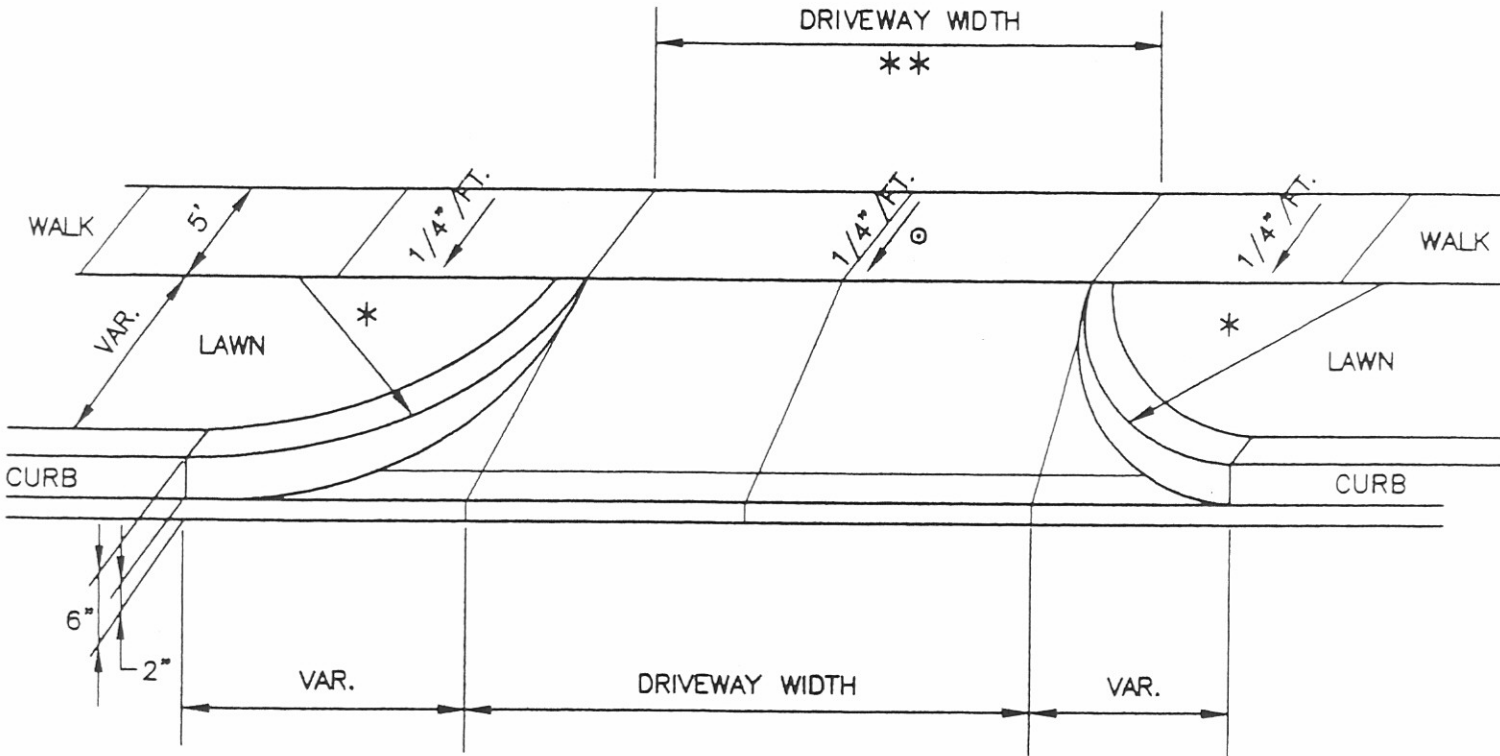

\* RADIUS = TREE LAWN WIDTH + 6" CURB  
 \*\* MATCH EXISTING DRIVE WIDTH UNLESS OTHERWISE DIRECTED.

**ISOMETRIC VIEW OF DRIVE OR ALLEY WITH CURB RETURNS**

⊙ MAINTAIN SLOPE REGARDLESS OF WHETHER SIDEWALK IS PRESENT OR NOT.

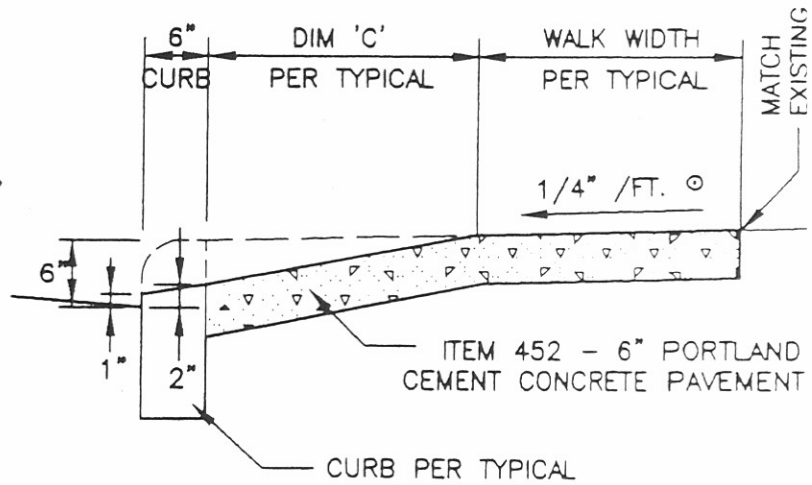
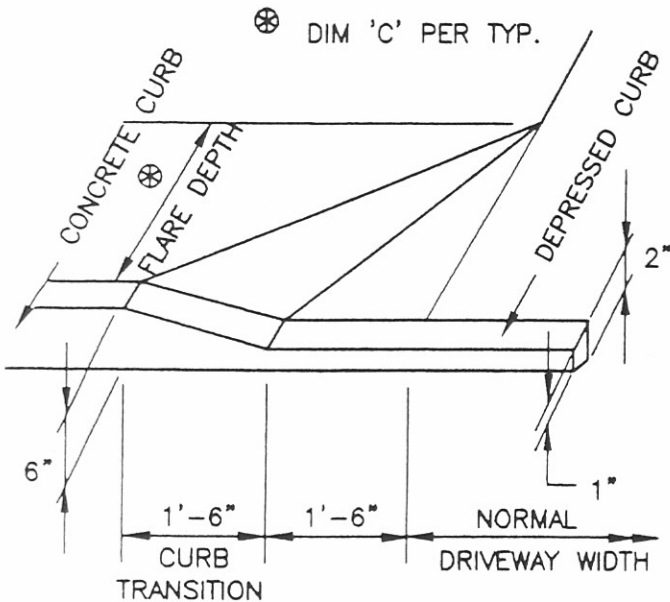

**DRIVE WITHOUT CURB RETURNS**

**DRIVEWAY PROFILE**

<p>CITY OF NEW PHILADELPHIA</p>	<p>STANDARD CONSTRUCTION DRAWING NO. <b>SD-17</b> REV. 8-93</p>
<p>DRIVEWAY TYPICAL DETAILS</p>	

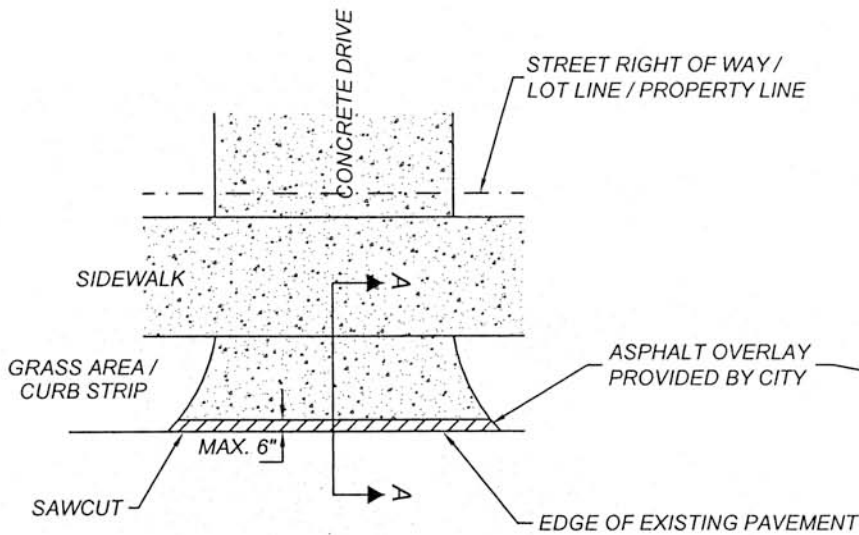

**PLAN VIEW**  
TYPICAL STREET

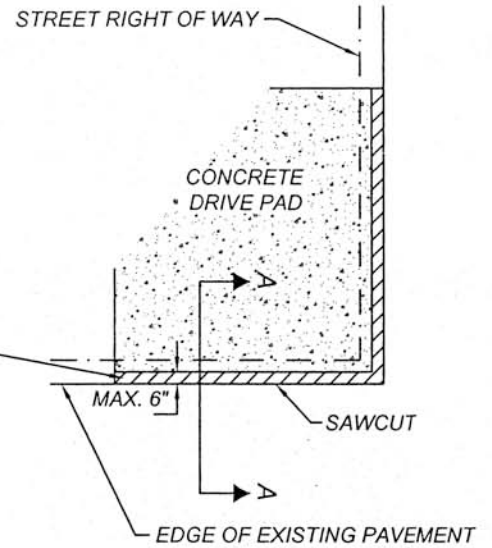

**PLAN VIEW**  
ALLEY OR AREAS WITH NO CURB STRIP

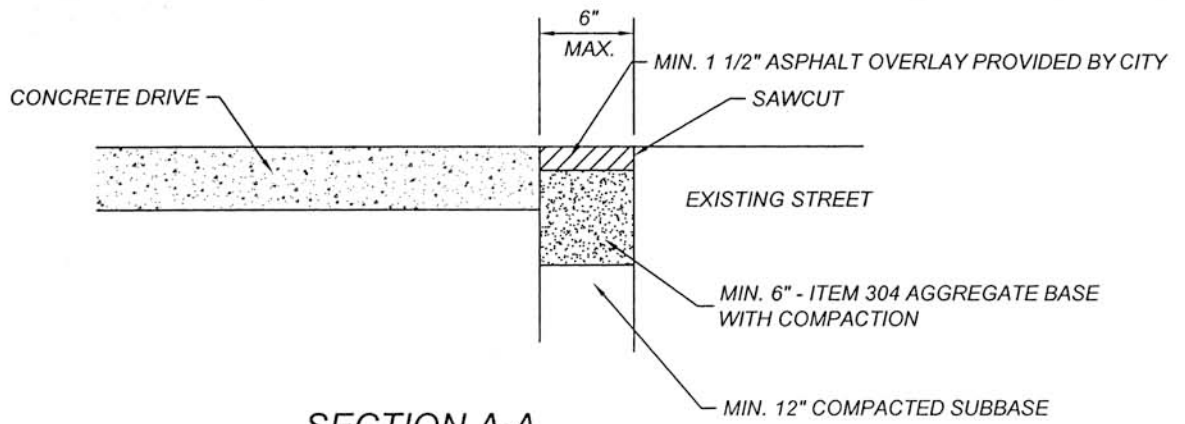

**SECTION A-A**

NOTE: TRIM RAGGED EDGES ON OLD ASPHALT TO PROVIDE A SUBSTANTIALLY STRAIGHT LINE JOINT BETWEEN OLD AND NEW ASPHALT SURFACES.

\\Alpha\alpha-data\Data\NEW PHILADELPHIA PROJECTS\Standard Drawings\SD-18.dwg, 6/1/2012, 10:51:00 AM

<b>CITY OF NEW PHILADELPHIA</b>		STANDARD CONSTRUCTION DRAWING NO. <b>SD-18</b> 5-2012
DRIVEWAY / STREET TRANSITION DETAIL		

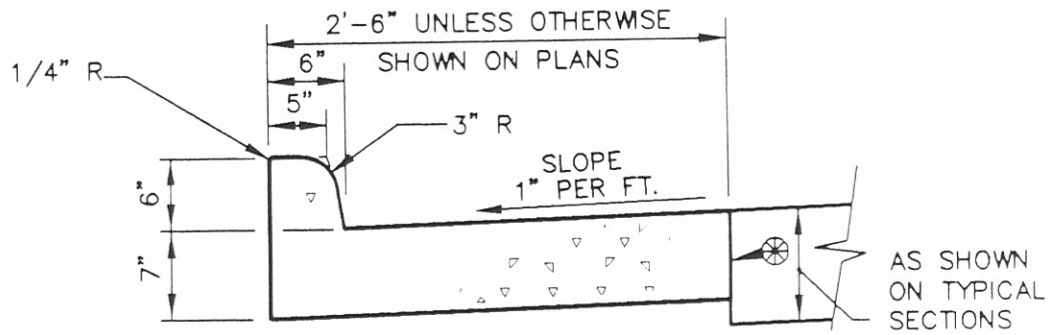

**TYPE 2 COMBINATION CONCRETE CURB & GUTTER**

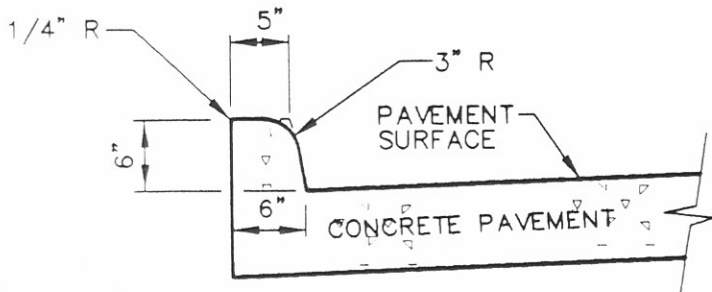

**TYPE 2A-INTEGRAL  
CONCRETE CURB**

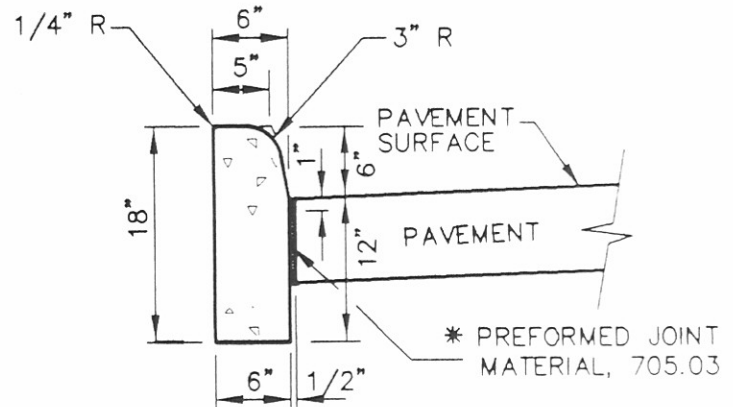

**TYPE 6-CONCRETE CURB**

**NOTES:**

JOINTS: WHEN RIGID PAVEMENT IS CONSTRUCTED, ONE INCH PAVEMENT EXPANSION JOINTS SHALL EXTEND UP TO TOP OF THE CURB AND BE CONSTRUCTED IN THE CURB AND GUTTER SECTION IN SUCH A MANNER THAT JOINT SEAL WILL EXTEND FULL WIDTH OF GUTTER AND INTO CURB FACE A SUFFICIENT DISTANCE TO SEAL THE JOINT TO AN ELEVATION AT LEAST TWO (2) INCHES ABOVE FLOW LINE OF GUTTER. INSTALL DOWEL BARS IN THE CURB AND GUTTER SECTION AT EXPANSION JOINTS IDENTICAL WITH JOINTS IN PAVEMENT. ALL JOINTS CONSTRUCTED PERPENDICULAR TO EDGE OF CURB AND SURFACE OF THE PAVEMENT. TRANSVERSE EXPANSION JOINT MATERIAL TO MEET REQUIREMENTS OF 705.03

\* EXPANSION JOINT MATERIAL AND JOINT SEALER IS NOT REQUIRED FOR PORTION OF CURB ADJACENT TO FLEXIBLE TYPE PAVEMENT. BOTH MATERIALS REQUIRED AS SHOWN FOR FULL HEIGHT OF RIGID PAVEMENT AND CONCRETE BASES.

⊕ PROVIDE BUTT JOINTS BETWEEN COMBINED CURB AND GUTTER AND NEW RIGID PAVEMENT WITH TIE BARS OR HOOK BOLTS SPACED AT FIVE FOOT INTERVALS. WHEN COMBINED CURB AND GUTTER ADJOINS NEW RIGID BASE OR EXISTING RIGID BASE OR PAVEMENT TO BE SURFACED WITH BITUMINOUS MATERIAL, A BUTT SHALL BE PROVIDED, BUT TIE BARS, HOOK BOLTS OR EXPANSION HOOK BOLTS TO BE OMITTED.

PROVIDE 1/4 INCH CONTRACTION JOINT CONSTRUCTED AT TEN (10) FOOT INTERVALS. JOINT MAY BE MADE WITH USE OF METAL SEPARATOR PLATES, BY USE OF A GROOVING TOOL OR SAWED. DEPTH OF JOINT SHALL AVERAGE 1/5 OR MORE OF CURB HEIGHT.

TOP OF CURB OVER RESIDENTIAL SEWER LATERAL AND WATER SERVICE LINE SHALL BE STAMPED OR ETCHED WITH A "W" AND "S" BEFORE NEW CONCRETE CURB CURES.

CITY OF NEW PHILADELPHIA	STANDARD CONSTRUCTION DRAWING NO.
CONCRETE CURBS AND COMBINED CURB AND GUTTER	SD-20
	REV. 2-99



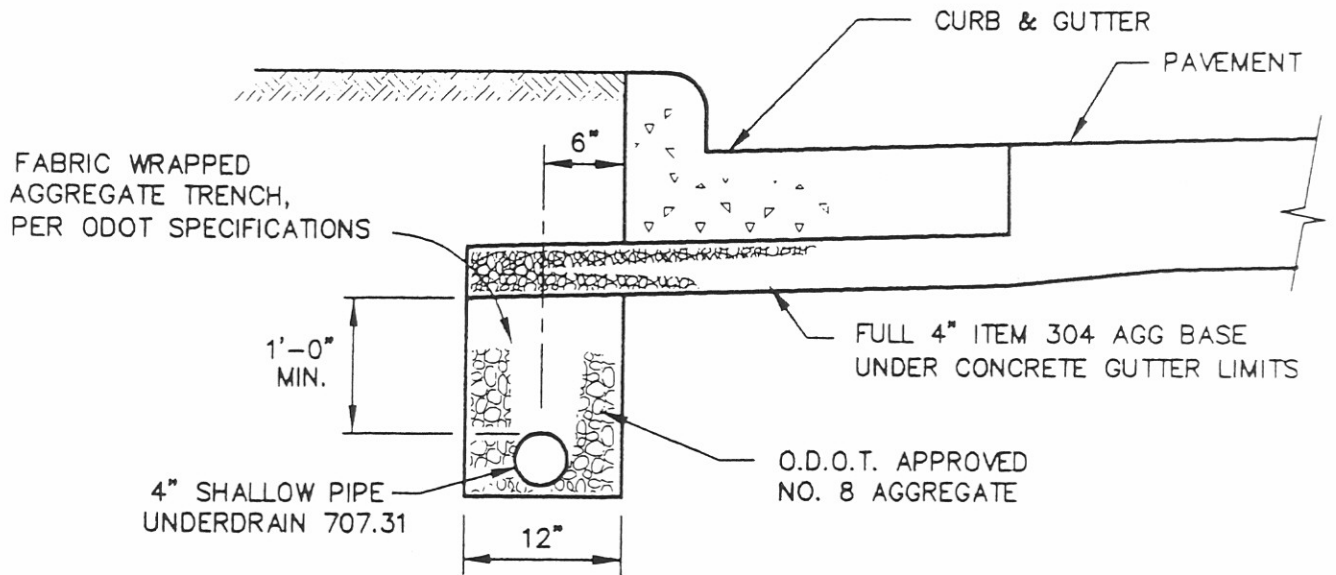

**WITH TYPE-2 OR TYPE 2-A CURB**

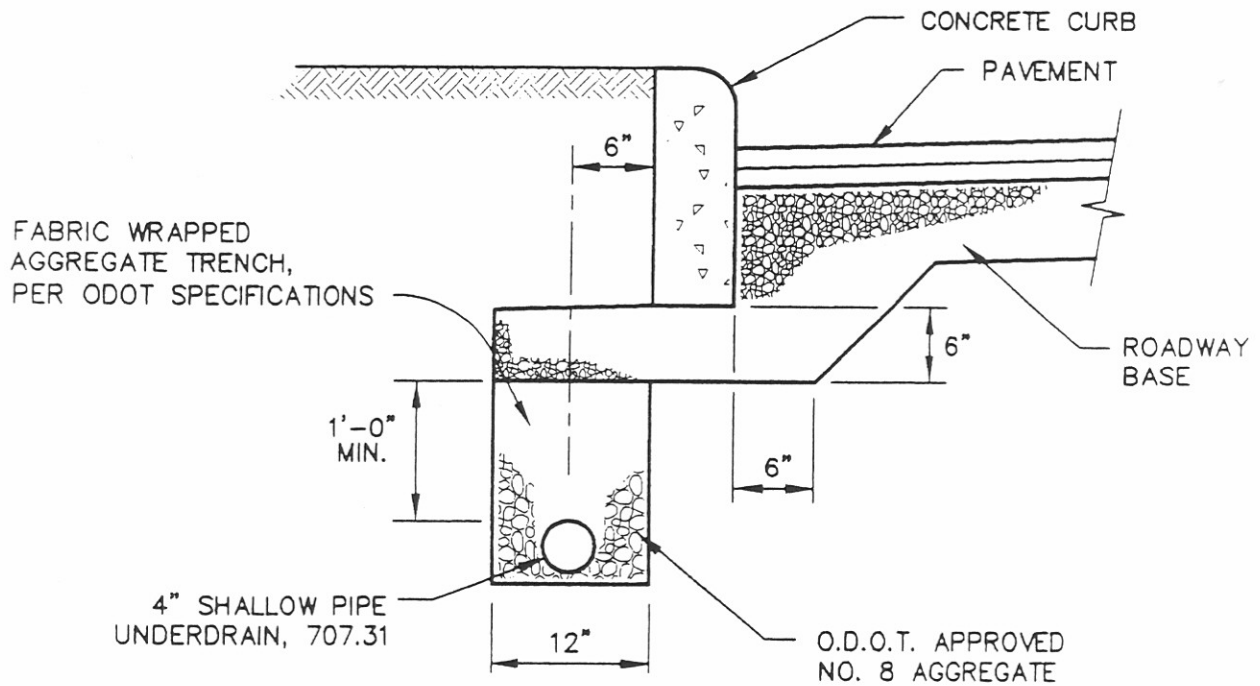

**WITH TYPE 6 CONCRETE CURB**

NOTE: MATERIALS & METHODS OF INSTALLATION IN ACCORDANCE WITH LATEST EDITION OF O.D.O.T. "CONSTRUCTION AND MATERIALS SPECIFICATIONS" ITEM 605. TRANSITION UNDERDRAIN DEPTH TO OUTLET AS REQUIRED.

CITY OF NEW PHILADELPHIA	STANDARD CONSTRUCTION DRAWING NO.
4" PIPE UNDERDRAIN DETAILS	SD-21 REV. 11-97

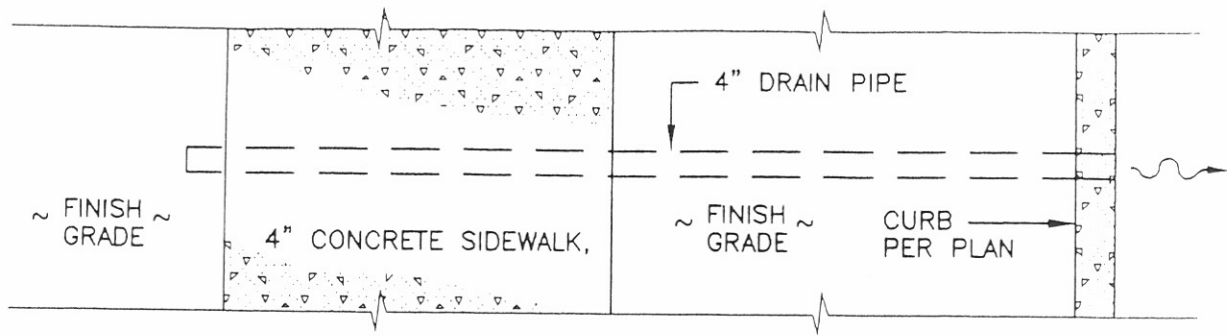

PLAN

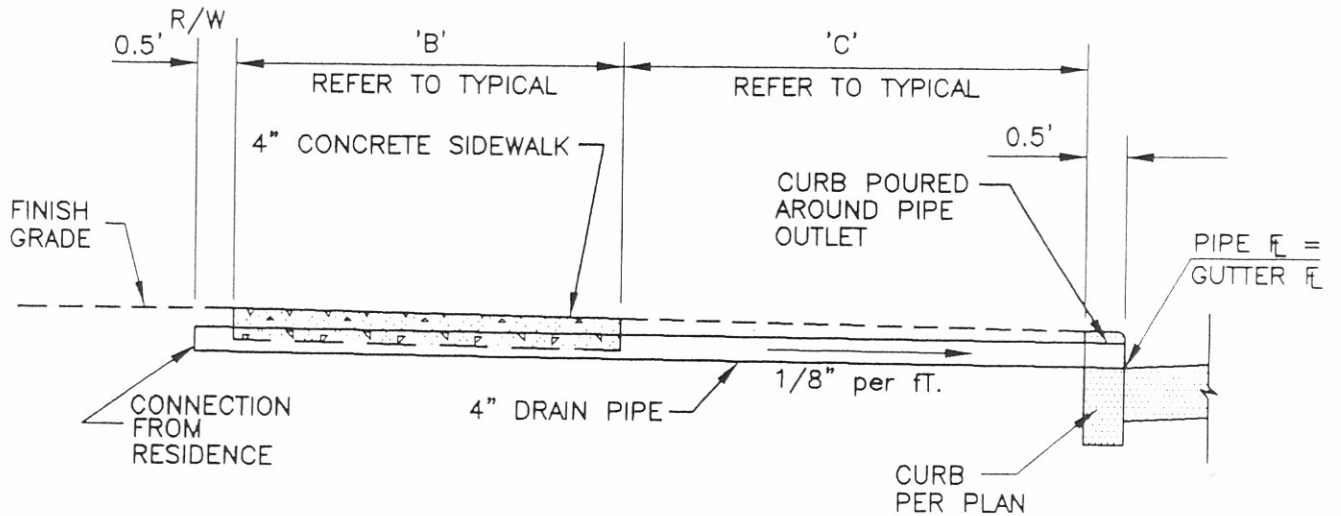

SECTION

NOTES:

1. ROOF DRAIN OUTLETS THRU CURB ARE NOT PERMITTED WHERE THERE IS NO STORM SEWER SYSTEM TO COLLECT RUN-OFF IN THE STREET.
2. CUTTING OF CURB FOR PLACEMENT OF ROOF DRAIN PIPING WILL NOT BE PERMITTED, UNLESS OTHERWISE AUTHORIZED BY THE BUILDING INSPECTOR.
3. WHERE ROOF DRAIN PIPE OUTLETS THRU CURB ARE PERMITTED, CONTRACTOR SHALL LOCATE AND PLACE DRAIN PIPE PRIOR TO FORMING OF NEW CURB AND SIDEWALK.
4. CUT TRANSVERSE JOINT IN WALK OVER CENTER OF ROOF DRAIN PIPE, EITHER SAWED, TROWEL CUT OR FORMED TO A DEPTH NOT LESS THAN ONE INCH DEEP. JOINTS TO BE 1/8 INCH MIN. WDE AND SPACED NO MORE THAN FIVE (5) FEET MAXIMUM ON CENTERS THROUGH OUT LENGTH OF SIDEWALK.

CITY OF NEW PHILADELPHIA

THRU CURB ROOF DRAIN DETAILS  
WHEN CATCH BASINS ARE LOCATED ALONG CURB

STANDARD  
CONSTRUCTION  
DRAWING NO.

SD-22

REV. 11-00

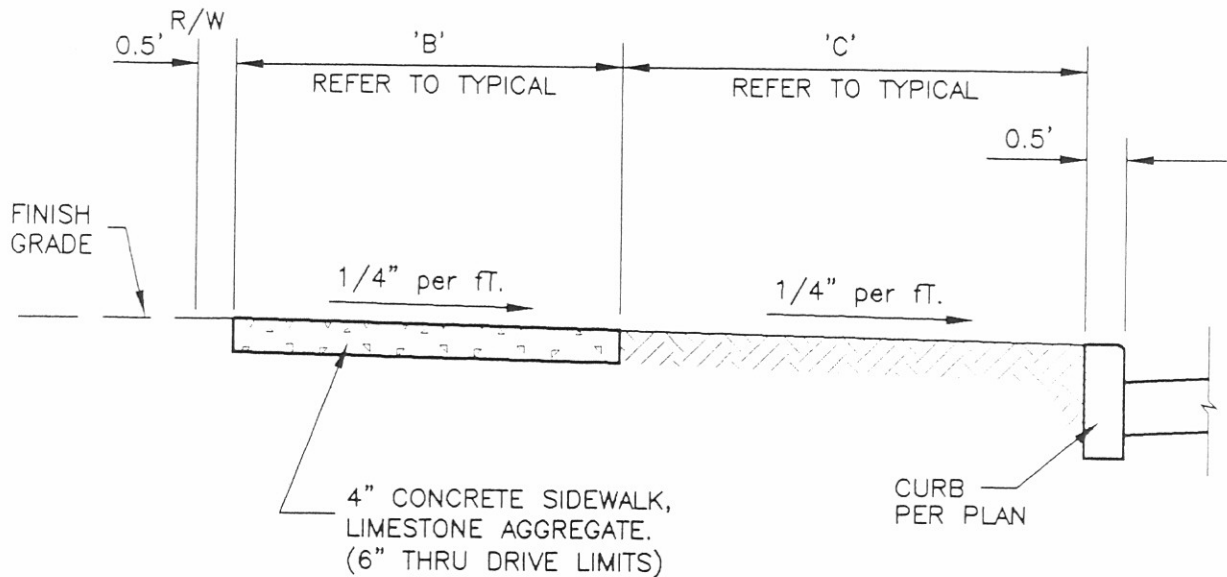

### TYPICAL SECTION

NOTES:

1. ALL NEW SIDEWALK CONCRETE TO BE AIR-ENTRAINED, LIMESTONE AGGREGATE AND FOUR (4) INCH MINIMUM THICKNESS. SIX (6) INCHES MINIMUM THICKNESS WITHIN DRIVEWAY LIMITS.
2. CONTRACTOR TO INSTALL CONCRETE SIDEWALK WHEN NECESSARY CONNECTING STREET SIDEWALK TO THE PROPERTY OWNERS HOUSE WALK. (WIDTH AND LENGTH WILL VARY)
3. PROVIDE 1/2 INCH EXPANSION JOINT MATERIAL AT JOINTS NOT EXCEEDING SIXTY FOOT INTERVALS.
4. CUT TRANSVERSE JOINTS IN WALK, EITHER SAWED, TROWEL CUT OR FORMED TO A DEPTH NOT LESS THAN 1/5 OF WALK THICKNESS. JOINTS TO BE 1/8 INCH MIN. WDE AND SPACED NO MORE THAN FIVE (5) FEET MAXIMUM ON CENTERS THROUGH OUT LENGTH.
5. LIGHT BROOM FINISH ON SURFACE.

CITY OF NEW PHILADELPHIA	STANDARD CONSTRUCTION DRAWING NO.
CONCRETE SIDEWALK DETAILS	SD-23
	REV. 10-99

# CITY OF NEW PHILADELPHIA

## HANDICAP ACCESS CURB RAMPS (ODOT STANDARD BP-7.1)

STANDARD  
CONSTRUCTION  
DRAWING NO.  
**SD-24**  
REV. 01-00

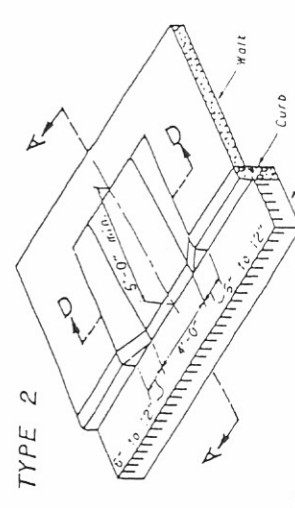
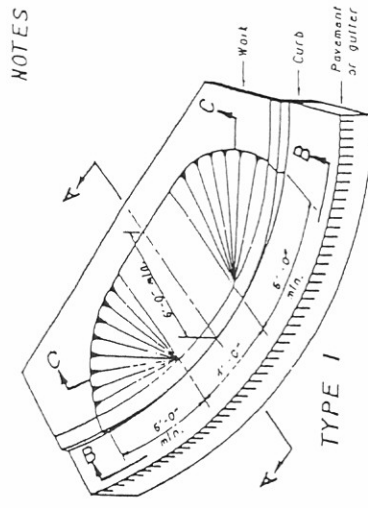
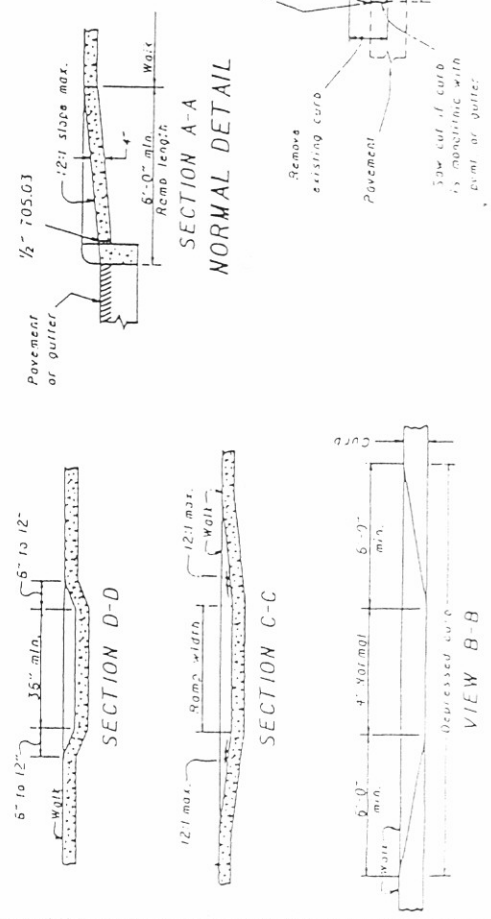
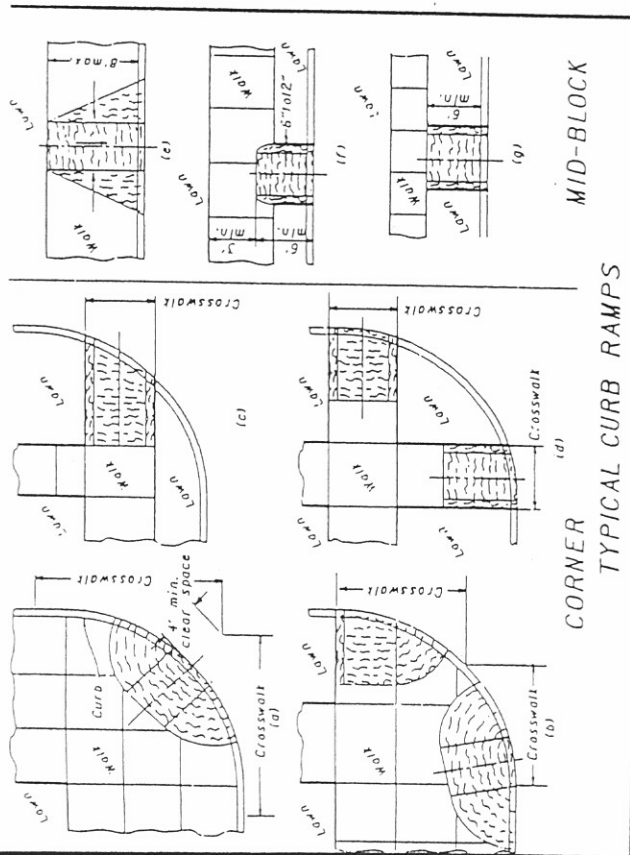

Adjacent to P.C.C. - 1/2" inch pre-formed joint material - CUS 705.03 with joint scale - Dwg. BP-5.1.

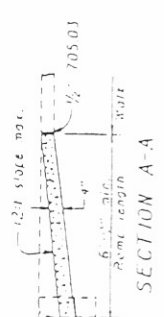

EXISTING WALK DETAIL

**PAYMENT:** Wait and curb, Items 608 and 609, shall be measured through the curb ramp in accordance with their respective items. Item 609 under Curb Ramp constructed in new curb and wait shall include the cost of any additional materials, grade for curbs and finishing, Item 608, square foot Curb Ramp, constructed in existing curb and wait shall include the cost of furnishing all materials, grading, forming, and finishing of the curb and wait of the curb ramp. Removal of existing curb and wait shall be paid for under Item 202.

**SURFACE TEXTURE:** shall be obtained by coarse brooming transverse to the slopes and shall be rougher than adjacent wait.

**JOINTS:** shall be provided in the curb ramp as extensions of wait joints and consistent with 608.03 requirements for a new concrete curb. A 1/2" inch 705.03 expansion joint filler shall be installed above the edge of ramps built in existing curbs. The edge, as shown on this drawing, indicate the ramp, as shown slope changes and are not necessarily joint lines.

**DIMENSIONS, LOCATION AND TYPE OF CURB RAMP:** may be modified as directed by the engineer in accordance with the following:

- TYPE of curb ramp built shall be the type that best fits the location unless a type is specified in the plans.
- Type 1 is preferred because of the flatter side slopes. Any combination of Type 1 and 2 side slopes on opposite sides of a ramp may be used to best fit the site conditions.
- TYPE 1 Curb Ramps (Flared sides) should be used at locations where pedestrians must wait across the ramp at an angle. Typical Type Ramps (a, b, and c) are examples.
- Used where pedestrians must wait across or perpendicular to the normal line of the ramp. Sides of these ramps must be parallel to the pedestrian flow. Typical Curb Ramps (d, f) and (g) are examples.

- SLOPE of the ramp toward the curb is preferred to be 12:1 or flatter (slat to the horizontal) but the maximum slope shall be 12:1 relative to the existing or proposed walk slope. The minimum ramp length is 6 ft. from the back of a 6 in curb and may be increased where feasible to obtain a flatter ramp slope or to better blend with the wait configuration.

- WIDTH of ramp shall normally be 4 ft. but minimum width of 3 ft. may be used to better blend with the configuration or where site conditions warrant. Conditions include narrow waits, pole foundations, drainage inlets, etc. The width may be labeled.

- WALK THICKNESS in the ramp slopes shall be 4 in. minimum or thicker as necessary to match adjacent wait thickness.

BUREAU OF LOCATION AND DESIGN OHIO DEPARTMENT OF TRANSPORTATION	
DATE 7-20-53	40 10 S.
CURB RAMPS	
STANDARD CONSTRUCTION DRAWING	BP-7.1
E. K. ULL	

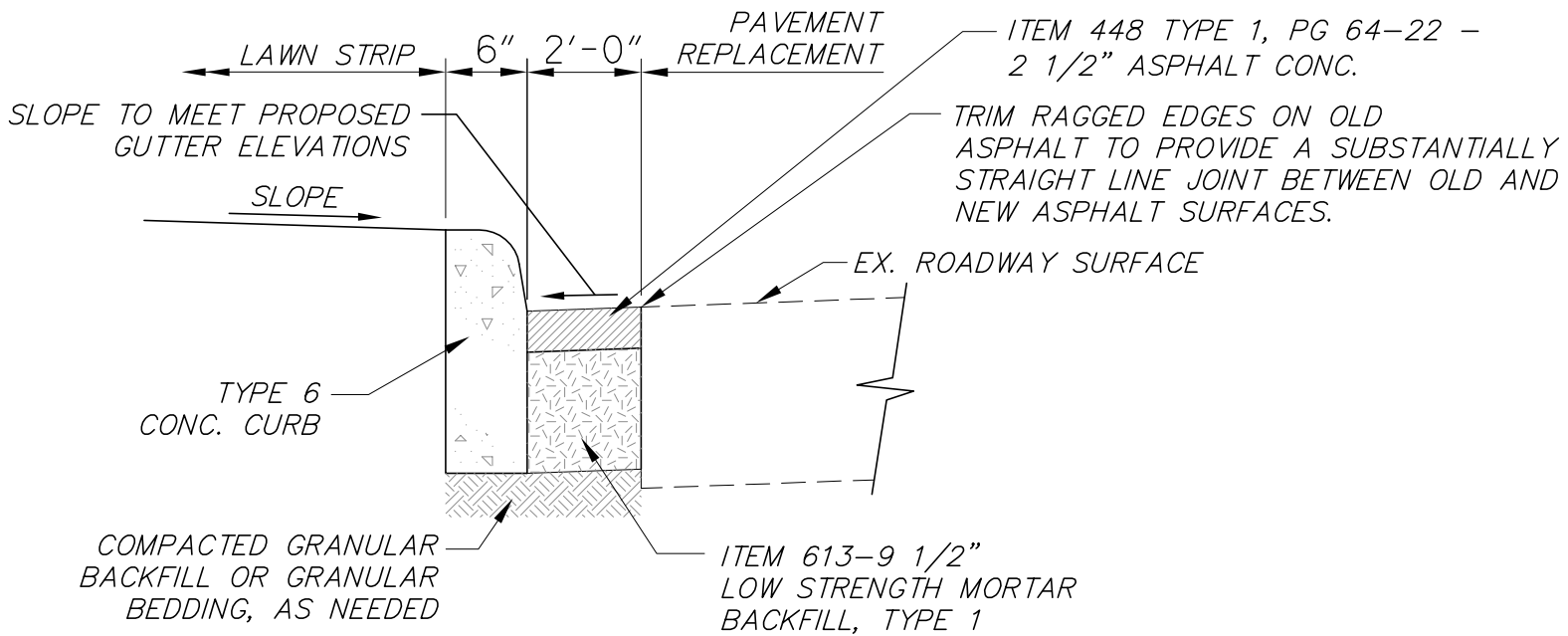

NOT TO SCALE

CITY OF NEW PHILADELPHIA	STANDARD CONSTRUCTION DRAWING NO.
CONCRETE CURB PAVEMENT REPLACEMENT DETAILS	RAY-SD-25A REV. 5-09

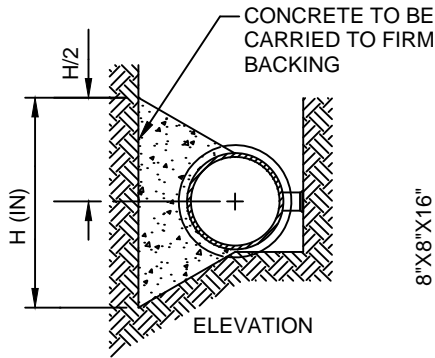
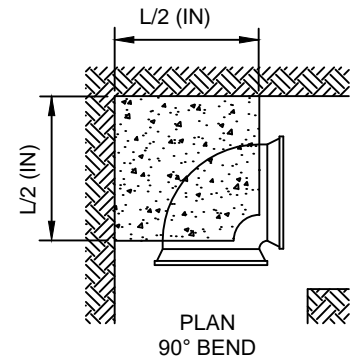
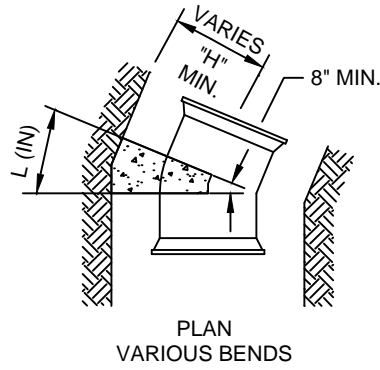
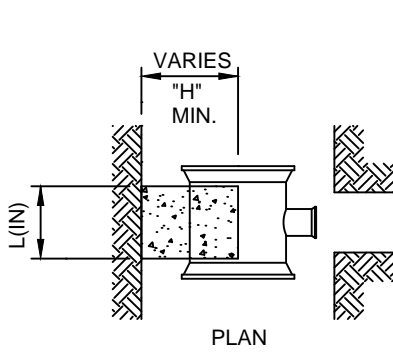

TEE

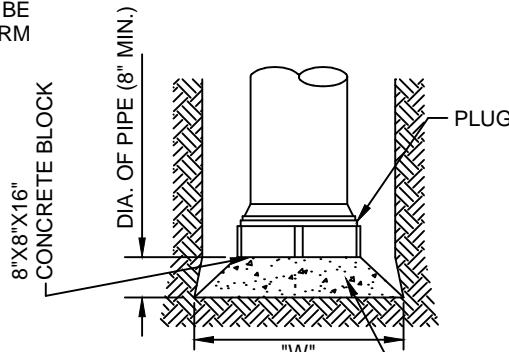

PLACE FILL CONCRETE  
"W" = MAXIMUM TRENCH WIDTH  
PER SD-118, SYMMETRICAL  
ABOUT C<sub>L</sub> OF PIPE.  
HEIGHT = 2 X DIA. OF PIPE.

END OF LINE

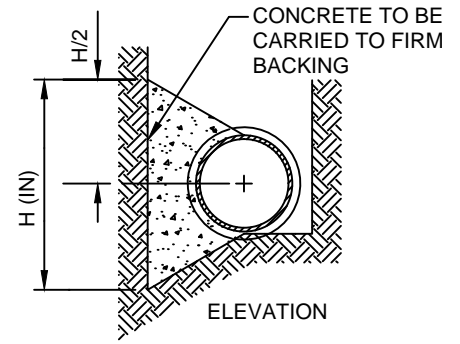

HORIZONTAL BENDS

L & H DIMENSIONS ARE IN INCHES

R U N	BRANCH															
	2"		3"		4"		6"		8"		10"		12"			
	L	H	L	H	L	H	L	H	L	H	L	H	L	H		
2"	6	5														
3"	6	5	8	6												
4"	6	5	8	6	12	7										
6"	6	6	8	6	10	8	15	12								
8"	6	8	6	8	10	8	15	12	18	18						
10"	6	10	6	10	8	10	15	12	18	18	22	22				
12"	6	12	6	12	7	12	15	12	18	18	22	22	24	29		
14"	6	14	6	14	6	14	13	14	18	18	22	22	26	27		

NOTE: USE FILL CONCRETE. DESIGN BASED  
ON A WORKING PRESSURE OF 125 PSI  
AND A SOIL BEARING OF 3000 LB./SQ. FT.

SIZE OF PIPE	DEGREE OF BEND							
	11 1/4°		22 1/2°		45°		90°	
	L	H	L	H	L	H	L	H
2"	4	3	4	4	5	4	10	5
3"	4	3	5	4	7	5	16	6
4"	5	4	7	5	10	6	20	8
6"	6	6	10	7	17	8	30	12
8"	8	8	14	9	19	13	36	18
10"	10	10	17	11	22	17	44	22
12"	12	12	19	15	24	22	48	29
14"	14	14	20	19	25	29	52	36
16"	16	16	20	24	27	35	58	42
18"	18	18	22	28	28	42	62	50
20"	20	20	25	30	32	46	68	56
24"	23	24	29	37	36	58	80	68

# CITY OF NEW PHILADELPHIA

## THRUST BLOCKING DETAILS HORIZONTAL BENDS

STANDARD  
CONSTRUCTION  
DRAWING NO.  
**SD-100**  
REV. 1-94

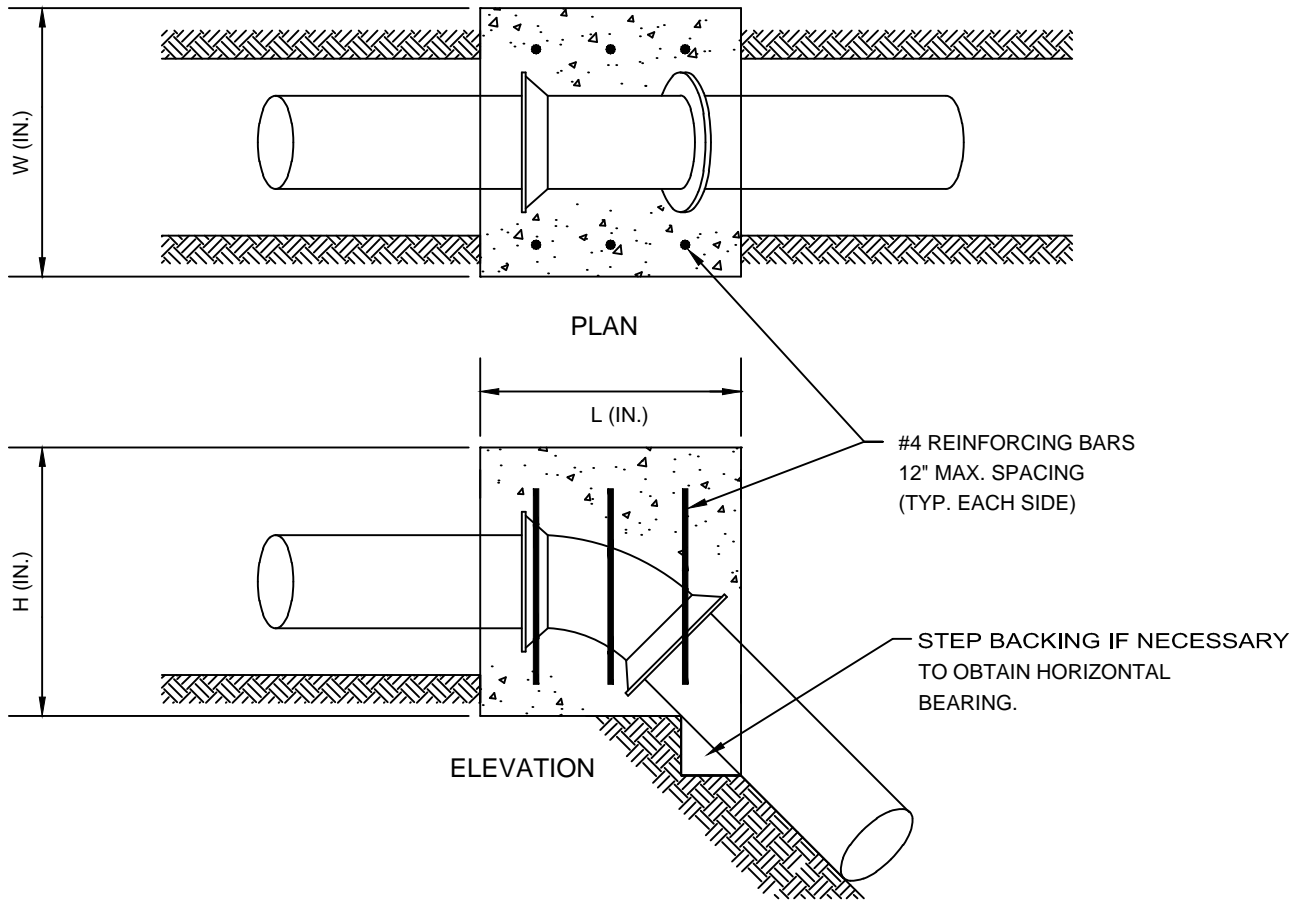

**NOTE:**

1. BLOCKING TO BE CENTERED ON BEND HORIZONTALLY.
2. ALL CONCRETE TO BE FILL CONCRETE.
3. L & W & H DIMENSIONS ARE IN INCHES.
4. BLOCKING DESIGN BASED ON A WORKING PRESSURE OF 125 PSI AND A SOIL BEARING OF 3000 LB./SQ. FT.

SIZE OF PIPE	DEGREE OF BEND											
	11 1/4°			22 1/2°			45°			90°		
	L	W	H	L	W	H	L	W	H	L	W	H
3"	12	18	15	13	24	15	18	30	16	25	30	20
4"	13	24	16	16	30	16	25	30	20	27	40	24
6"	15	36	18	27	36	18	30	44	24	36	45	36
8"	20	40	20	28	48	22	34	50	34	43	58	42
10"	24	44	22	32	54	27	40	55	40	51	64	50
12"	32	48	24	36	60	30	46	60	46	60	66	59
14"	34	54	26	40	60	38	54	60	53	66	73	66
16"	35	60	30	42	66	42	59	66	58	72	80	72
18"	36	66	32	48	66	46	66	66	65	75	94	74
20"	38	70	36	54	66	50	68	76	68	78	106	78
24"	42	72	44	60	72	60	78	84	77	90	114	90

# CITY OF NEW PHILADELPHIA

## THRUST BLOCKING DETAILS VERTICAL BENDS

STANDARD  
CONSTRUCTION  
DRAWING NO.

**SD-101**

REV. 6-92

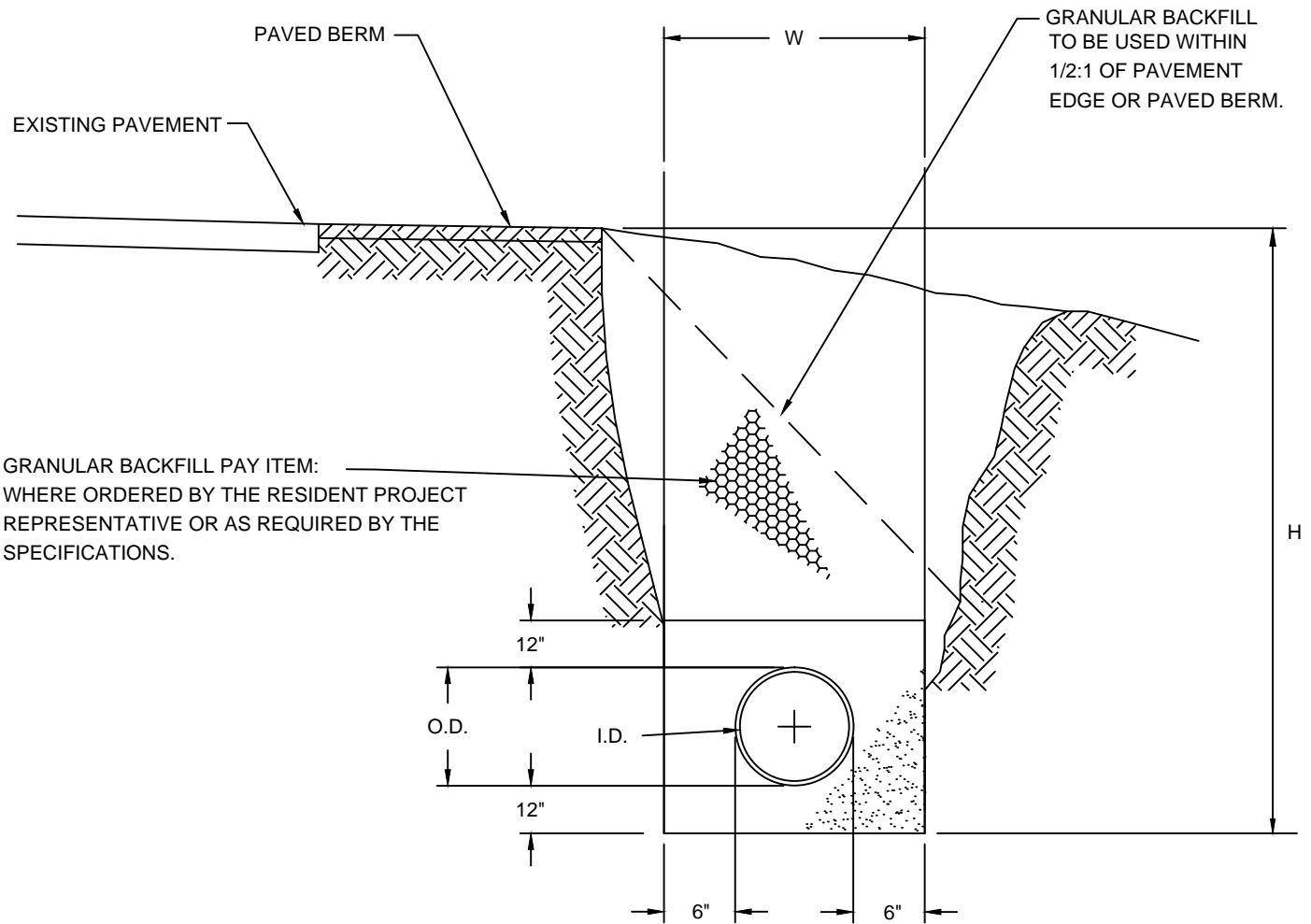

**LIMITS OF PAYMENT:**

PAYMENT SECTION IS 'W' x 'H'

THE TOP LIMIT OF 'H' IS THE BOTTOM OF PAVEMENT, BOTTOM OF BERM AGGREGATE BASE, TOP OF TRENCH, OR REQUIRED ELEVATION (WHERE THE TRENCH IS ONLY PARTIALLY BACKFILLED WITH GRANULAR BACKFILL).

THE BOTTOM LIMIT OF 'H' IS THE TOP OF THE GRANULAR BEDDING MATERIAL ACCORDING TO SD-116 OR SD-117 AS APPROPRIATE.

**NOTES:**

DUCTILE IRON WATER PIPE SHALL HAVE A MINIMUM OF 12" OF SAND GRANULAR BEDDING ABOVE AND BELOW THE INSTALLED WATER PIPE.

USE STONE FOUNDATION WHEN THE NATURAL FOUNDATION PROVES UNSUITABLE AS DETERMINED BY THE RESIDENT PROJECT REPRESENTATIVE AND IN ACCORDANCE WITH THE SPECIFICATIONS.

<b>CITY OF NEW PHILADELPHIA</b>		STANDARD CONSTRUCTION DRAWING NO. <b>SD-106</b> REV. 03-13
GRANULAR BACKFILL DETAIL FOR TRENCH		



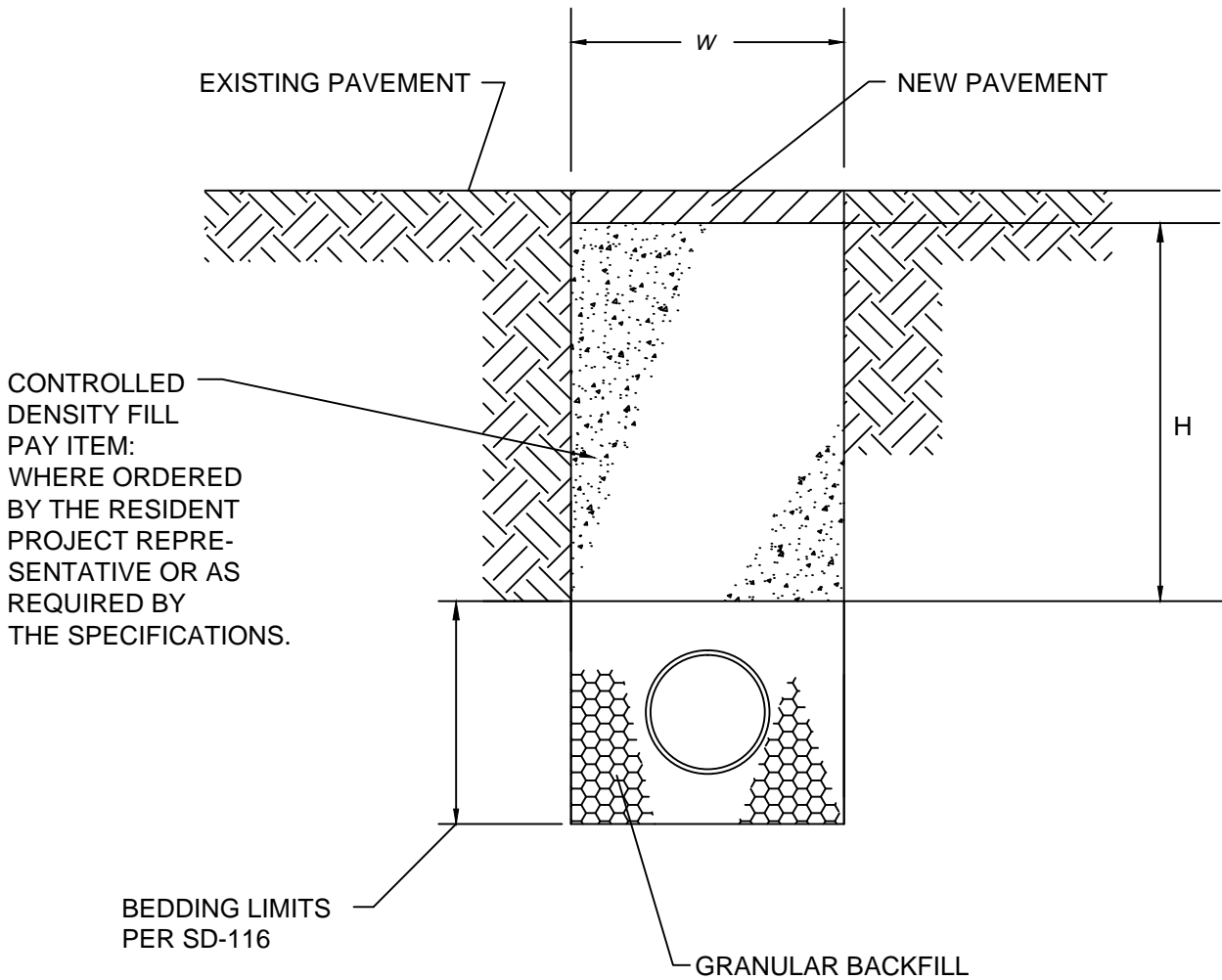

**LIMITS OF PAYMENT:**

PAVEMENT SECTION IS 'W' X 'H'. 'W' IS THE ALLOWABLE TRENCH WIDTH ACCORDING TO SD-118. THE TOP LIMIT OF 'H' IS THE BOTTOM OF PAVEMENT.

THE BOTTOM LIMIT OF 'H' IS THE TOP OF THE GRANULAR BEDDING MATERIAL.

<b>CITY OF NEW PHILADELPHIA</b>	STANDARD CONSTRUCTION DRAWING NO.
NOT TO SCALE CONTROLLED DENSITY FILL DETAIL FOR TRENCH	<b>SD-107</b> REV. 4-93

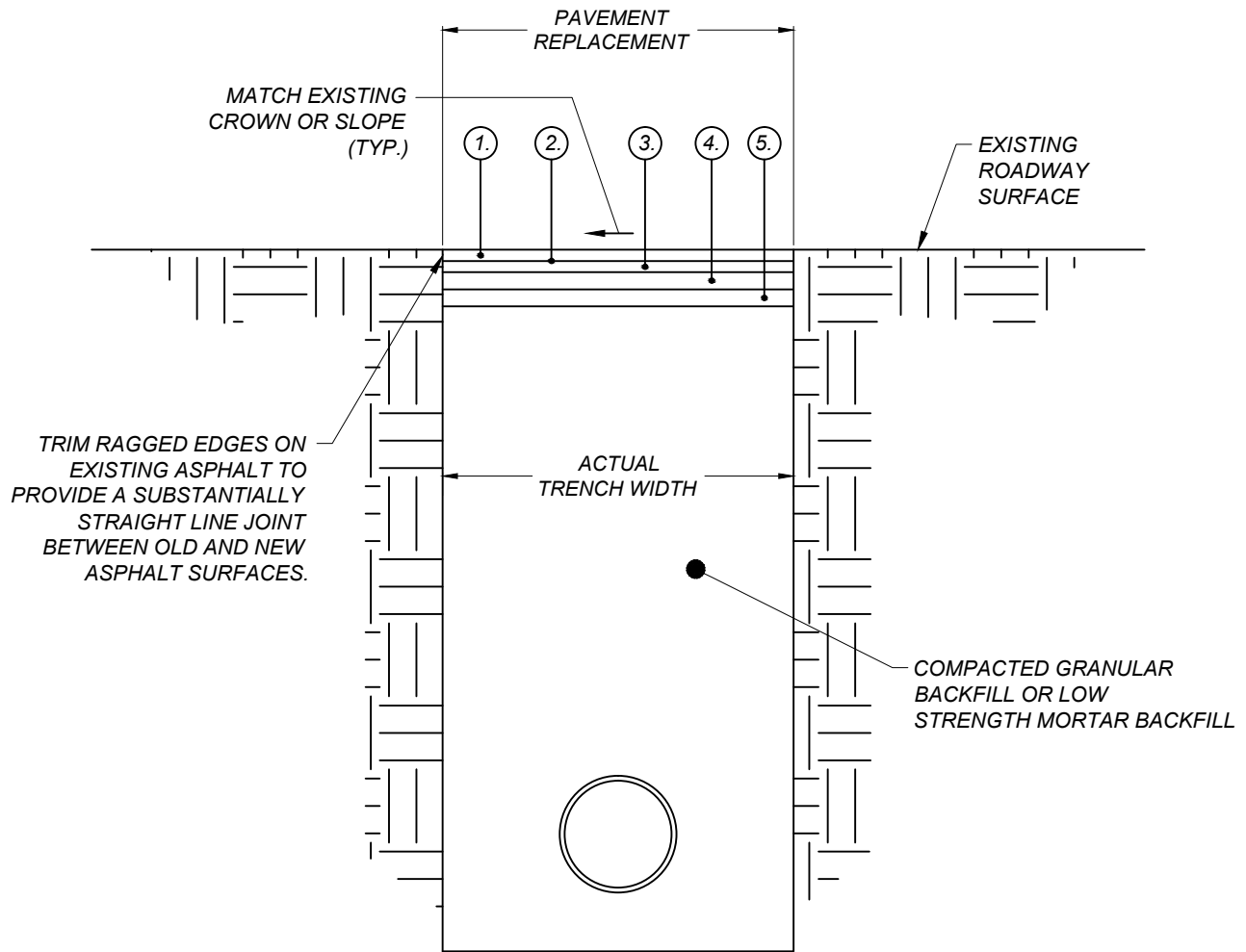

**LEGEND**

1. O.D.O.T. ITEM 448 - 1 1/4" ASPHALT CONCRETE SURFACE COURSE, TYPE 1
2. O.D.O.T. ITEM 407 - TACK COAT FOR INTERMEDIATE COURSE
3. O.D.O.T. ITEM 448 - 1 3/4" ASPHALT CONCRETE INTERMEDIATE COURSE, TYPE 1
4. O.D.O.T. ITEM 301 - 3" BITUMINOUS AGGREGATE BASE
5. O.D.O.T. ITEM 304 - 4" AGGREGATE BASE (LIMESTONE ONLY)

<p><b>CITY OF NEW PHILADELPHIA</b></p>	<p>STANDARD CONSTRUCTION DRAWING NO. <b>SD-109</b> REV. 03-13</p>
<p><b>PAVEMENT REPLACEMENT ASPHALT SURFACE ON AGGREGATE BASE</b></p>	

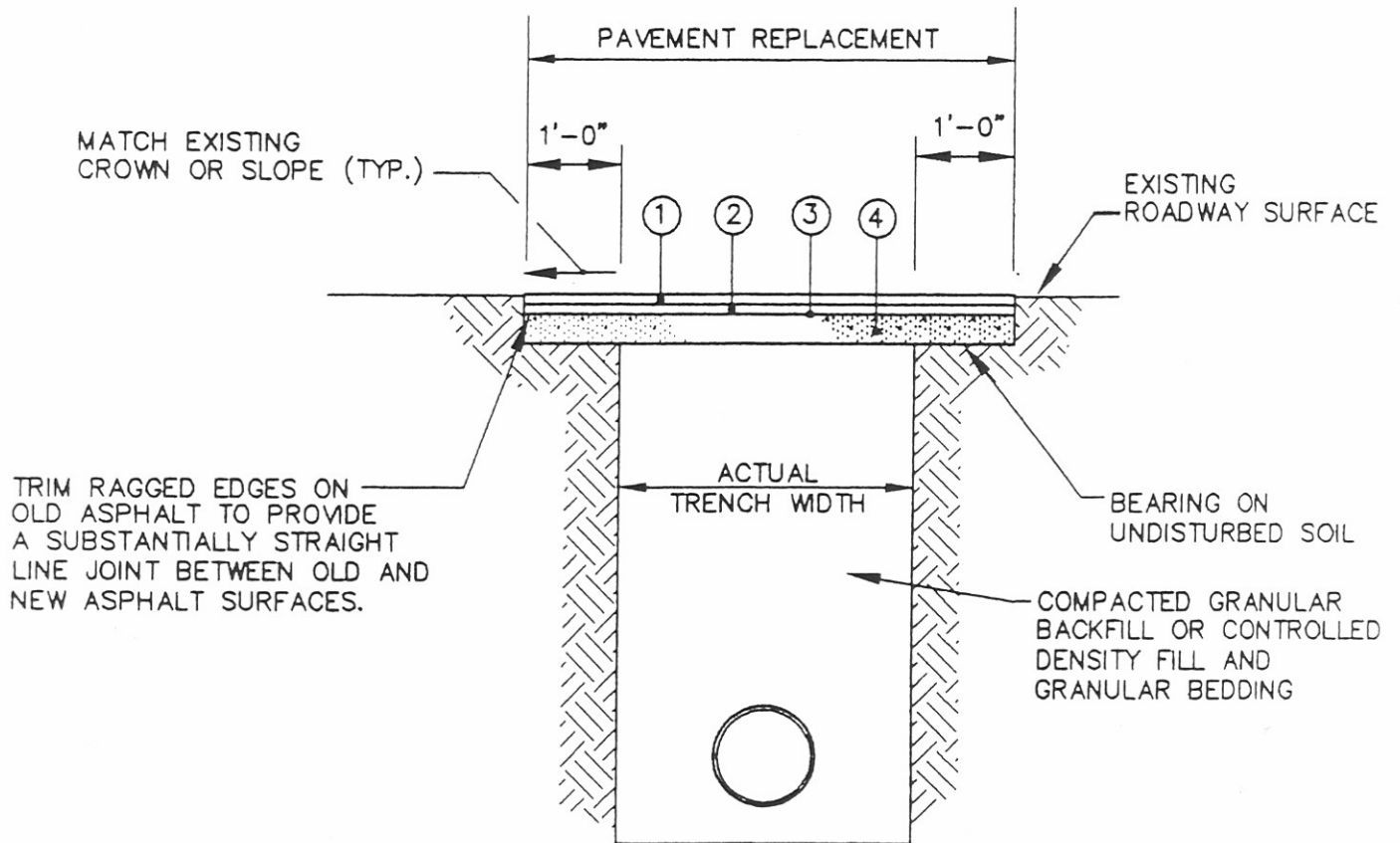

LEGEND

- ① O.D.O.T. ITEM 404 - 1 1/4" ASPHALT CONCRETE
- ② O.D.O.T. ITEM 402 - 1 3/4" ASPHALT CONCRETE
- ③ O.D.O.T. ITEM 407 - TACK COAT
- ④ O.D.O.T. ITEM 305 - 8" MIN. PORTLAND CEMENT CONCRETE BASE

<p>CITY OF NEW PHILADELPHIA</p>	<p>STANDARD CONSTRUCTION DRAWING NO.</p>
<p>PAVEMENT REPLACEMENT ASPHALT SURFACE ON CONCRETE BASE</p>	<p>SD-110</p>
	<p>REV. 9-95</p>

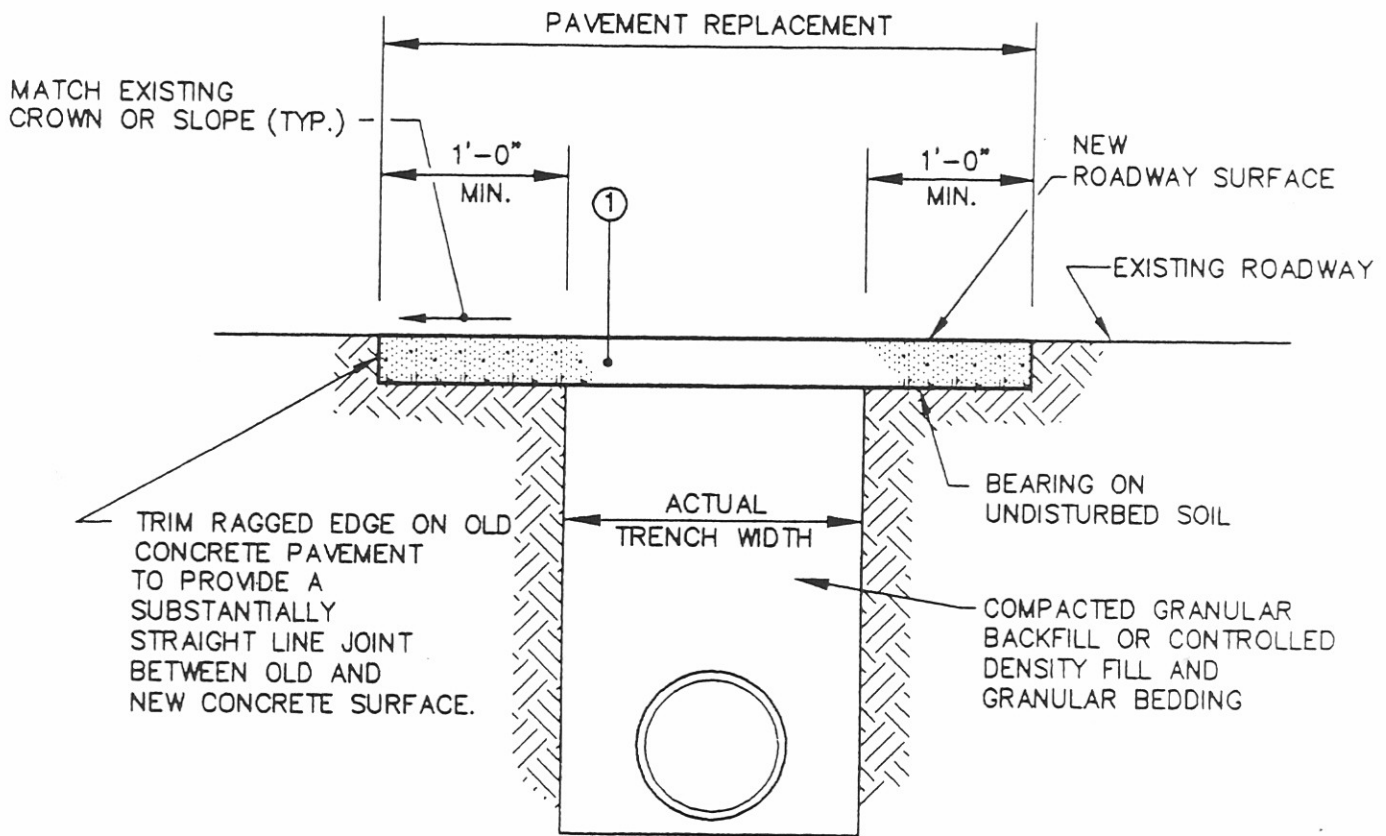

LEGEND

- ① O.D.O.T. ITEM 305 - (TYPE AND THICKNESS AS CALLED FOR IN SPECIFICATIONS)

CITY OF NEW PHILADELPHIA		STANDARD CONSTRUCTION DRAWING NO. <b>SD-115</b> REV. 6-92
PAVEMENT REPLACEMENT CONCRETE PAVEMENT		

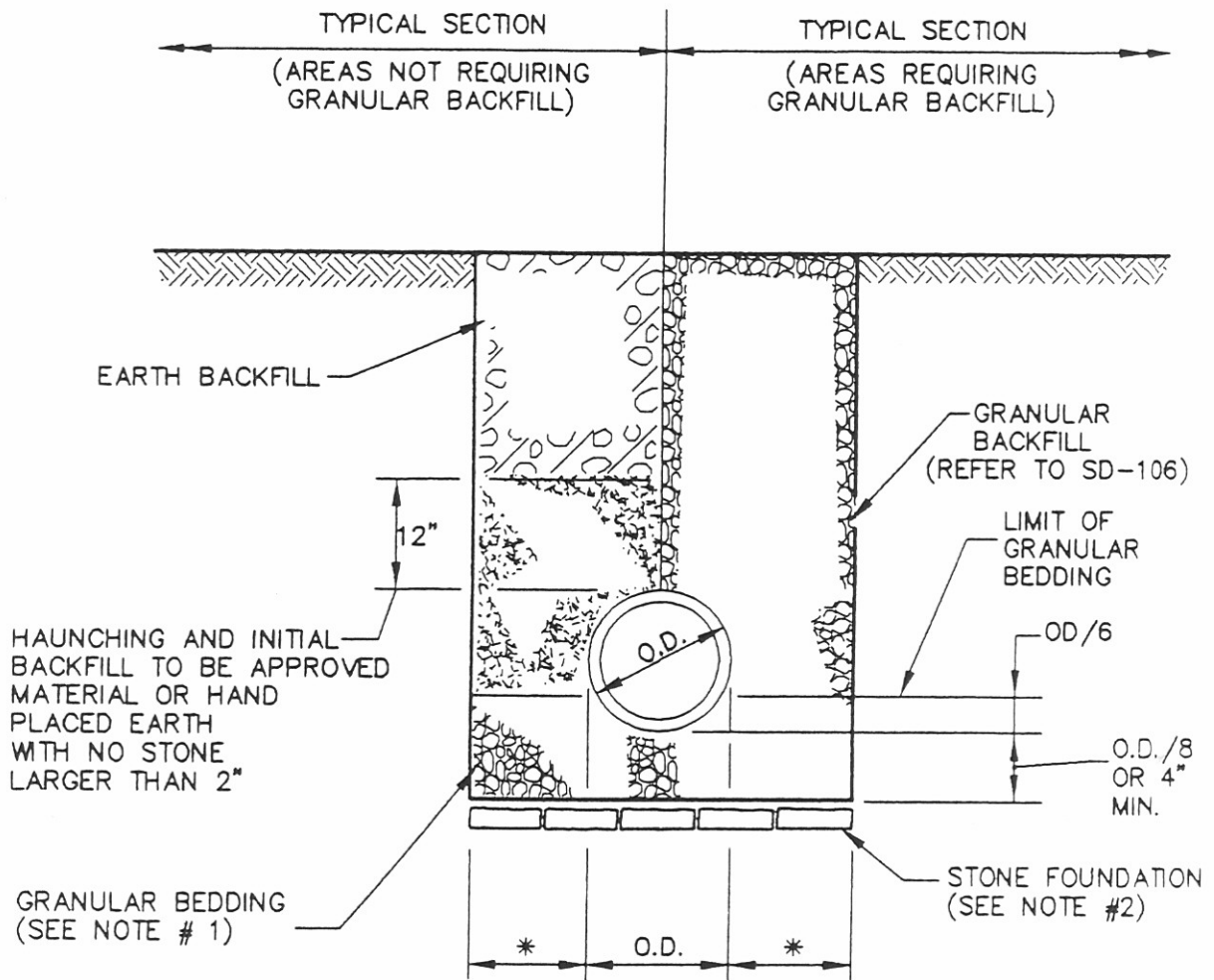

\* REFER TO SD-118

NOTES:

1. USE CLASS I, II, OR III GRANULAR BEDDING MATERIAL AS DESIGNATED IN THE APPLICABLE PIPE SPECIFICATION.
2. USE STONE FOUNDATION WHEN THE NATURAL FOUNDATION PROVES UNSUITABLE AS DETERMINED BY THE RESIDENT PROJECT REPRESENTATIVE AND IN ACCORDANCE WITH THE SPECIFICATIONS.

<p>CITY OF NEW PHILADELPHIA</p>	<p>STANDARD CONSTRUCTION DRAWING NO.</p>
<p>PIPE BEDDING / BACKFILL DETAIL FOR ALL RIGID SEWER PIPE</p>	<p>SD-116S</p>
	<p>REV. 10-94</p>

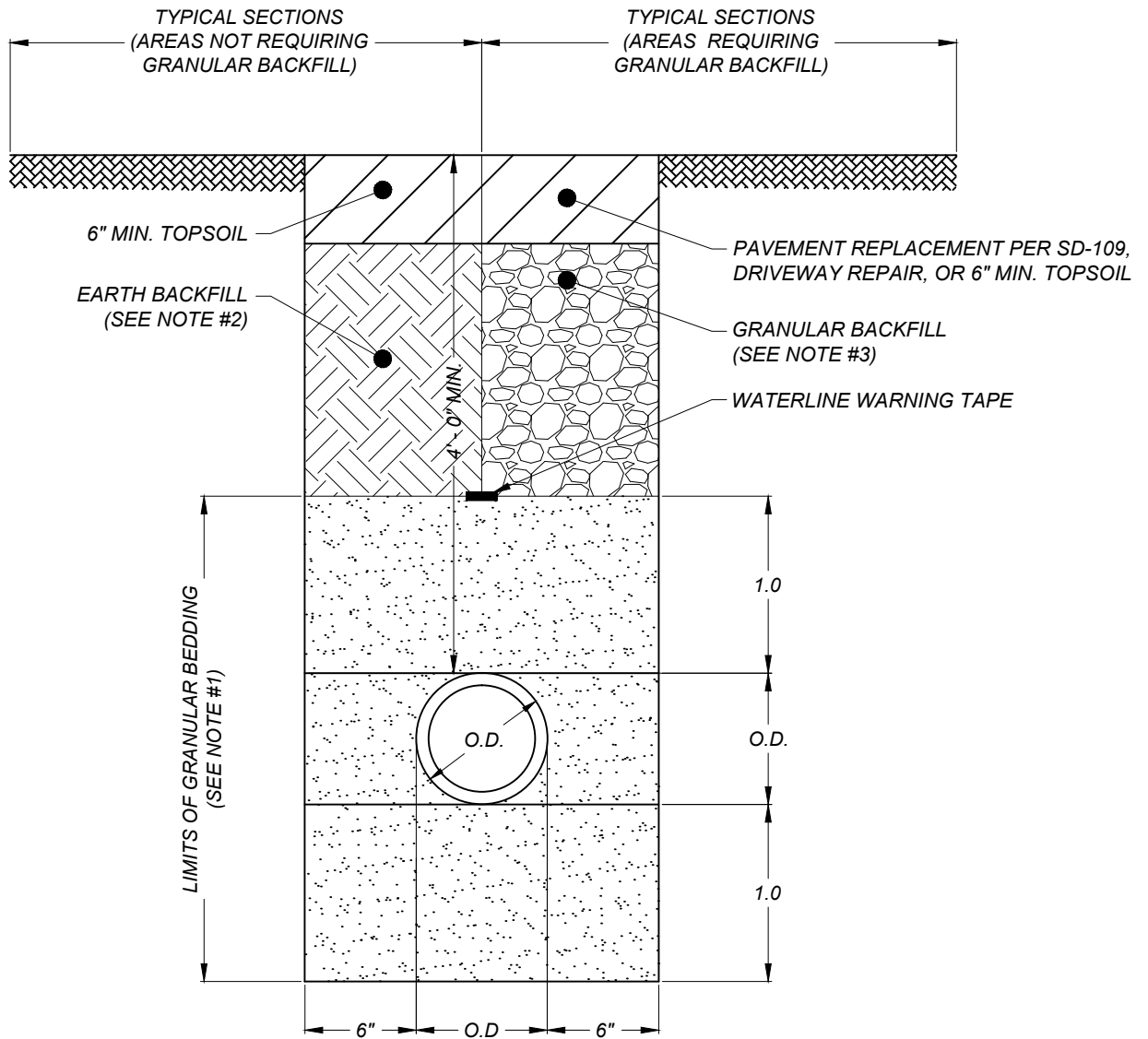

**NOTES:**

1. DUCTILE IRON WATER PIPE SHALL HAVE A MINIMUM OF 12" OF GRANULAR BEDDING ABOVE AND BELOW THE INSTALLED WATER PIPE. AGGREGATE FOR BEDDING IS SAND OR NO. 8 AGGREGATE
2. EARTH BACKFILL SHALL BE NATURAL SOIL FREE FROM STONES LARGER THAN TWO INCHES ACROSS THEIR GREATEST DIMENSION, TOPSOIL, VEGETATION, DEBRIS, RUBBISH, AND FROZEN MATERIAL, COMPACTED TO 95% OF ITS MAXIMUM DRY WEIGHT.
3. GRANULAR BACKFILL TO BE USED FOR STORM SEWERS LOCATED WITHIN THE LIMITS OF OR WITHIN A 1/2 TO 1 SLOPE OF EXISTING AND/OR PROPOSED ROADWAYS, PARKING AREAS, BUILDINGS, SIDEWALKS, AND/OR DRIVES, AND SHALL BE COMPACTED GRANULAR MATERIAL AS SPECIFIED IN ODOT ITEM 304.

**CITY OF NEW PHILADELPHIA**

**PIPE BEDDING / BACKFILL DETAIL  
FOR ALL RIGID WATER PIPE**

STANDARD  
CONSTRUCTION  
DRAWING NO.  
**SD-116W**  
REV. 03-13

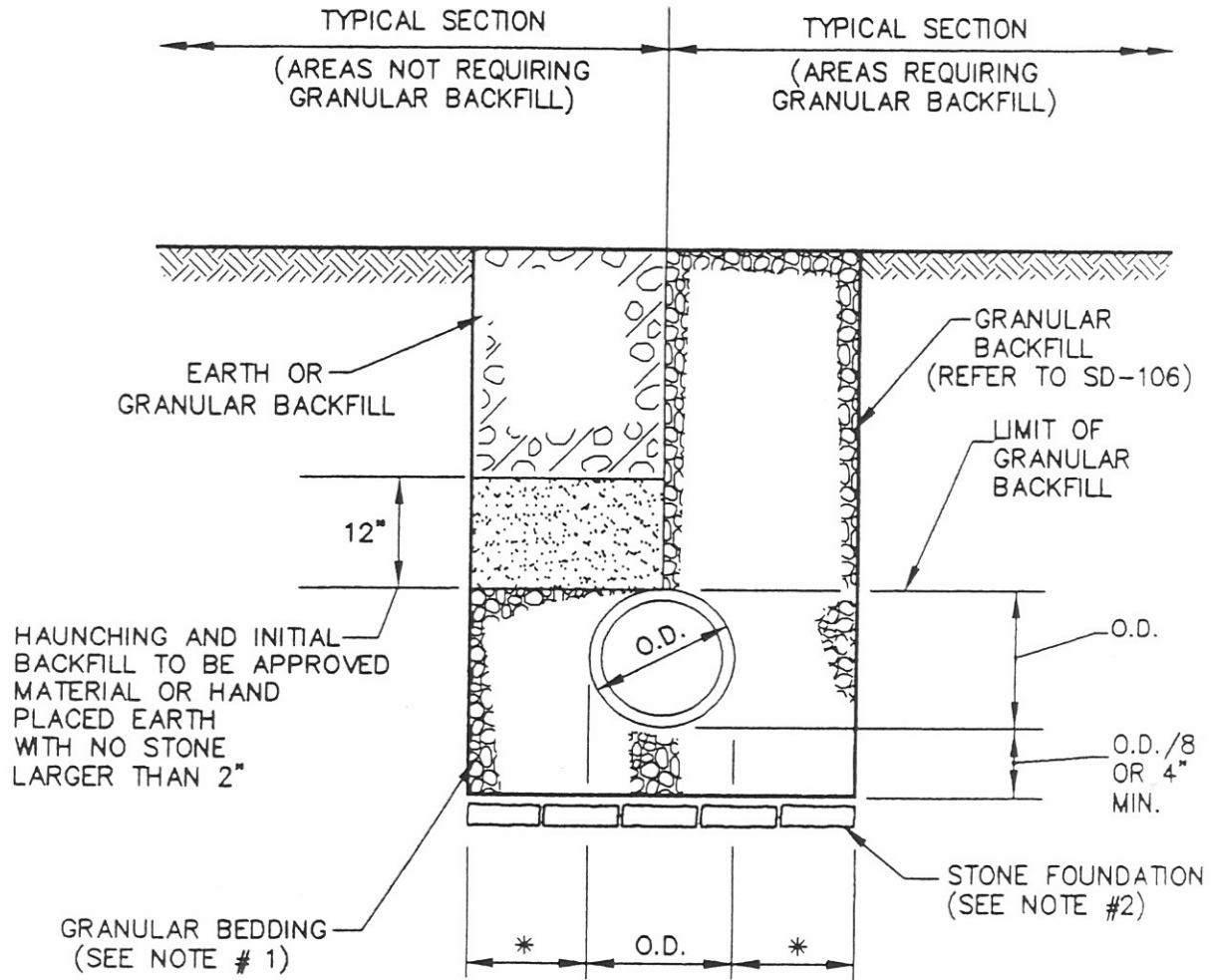

\* REFER TO DWG. 118

NOTES:

1. USE CLASS I, II, OR III GRANULAR BEDDING MATERIAL AS DESIGNATED IN THE APPLICABLE PIPE SPECIFICATION.
2. USE STONE FOUNDATION WHEN THE NATURAL FOUNDATION PROVES UNSUITABLE AS DETERMINED BY THE RESIDENT PROJECT REPRESENTATIVE AND IN ACCORDANCE WITH THE SPECIFICATIONS.

<p>CITY OF NEW PHILADELPHIA</p>	<p>STANDARD CONSTRUCTION DRAWING NO.</p>
<p>PIPE BEDDING / BACKFILL DETAIL FOR ALL FLEXIBLE SEWER AND WATER PIPE</p>	<p>SD-117</p>
	<p>REV. 11-92</p>

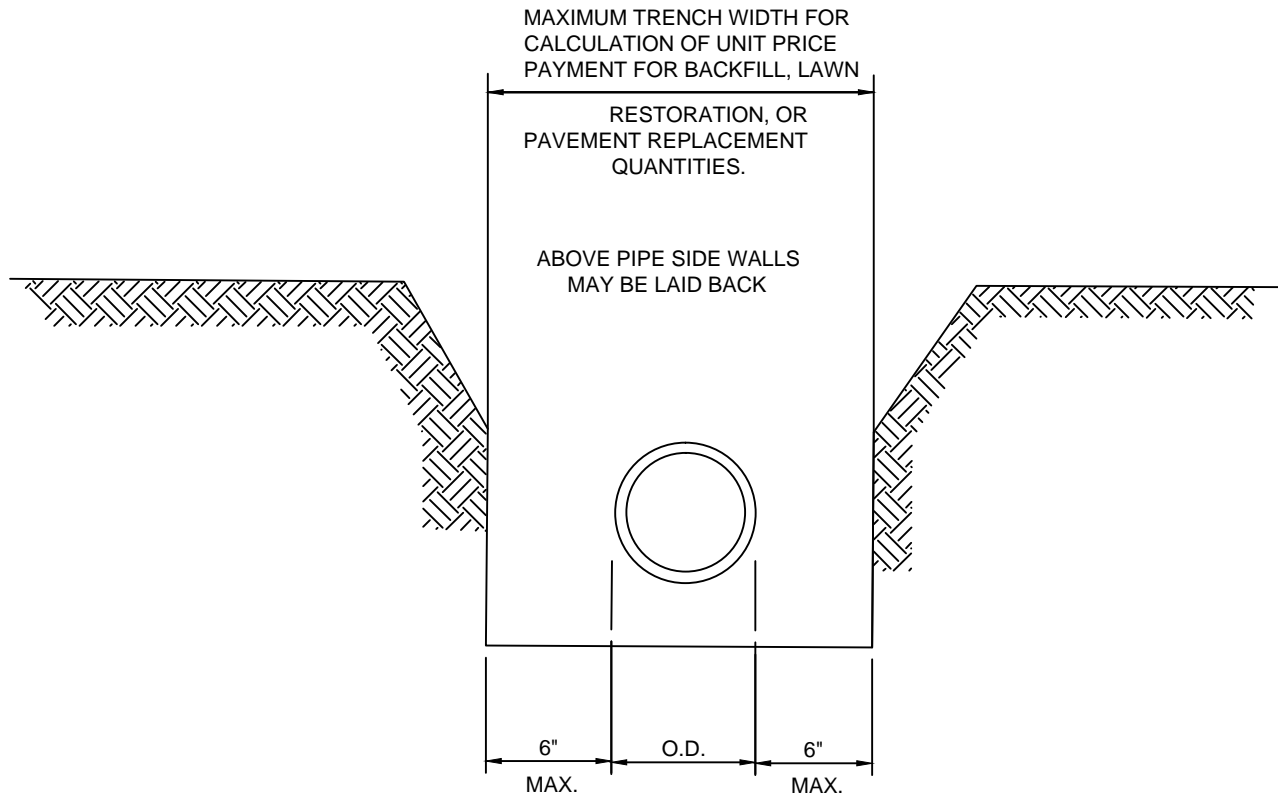

NOTES:

1. INCLUDE ANY COST ASSOCIATED WITH RESTORATION, REPAIR, AND REPLACEMENT, OUTSIDE THE ALLOWABLE TRENCH WIDTH IN THE COST OF WORK WITHIN THE ALLOWABLE TRENCH WIDTH.
2. THE WIDTH OF THE ACTUAL TRENCH BELOW THE ELEVATION OF THE TOP OF THE PIPE IS LIMITED TO WIDTHS ALLOWED BY THE APPLICABLE ASTM STANDARD FOR THE TYPE OF PIPE BEING USED.

**CITY OF NEW PHILADELPHIA**

TYPICAL TRENCH DETAIL

STANDARD  
CONSTRUCTION  
DRAWING NO.

**SD-118**

REV. 2-96



NEENAH R-1772-C OR EAST JORDAN 1022-2  
 MANHOLE FRAME AND SOLID COVER WITH  
 WORDS "STORM SEWER" OR "SANITARY SEWER"  
 AS APPROPRIATE CAST IN RAISED LETTERS.

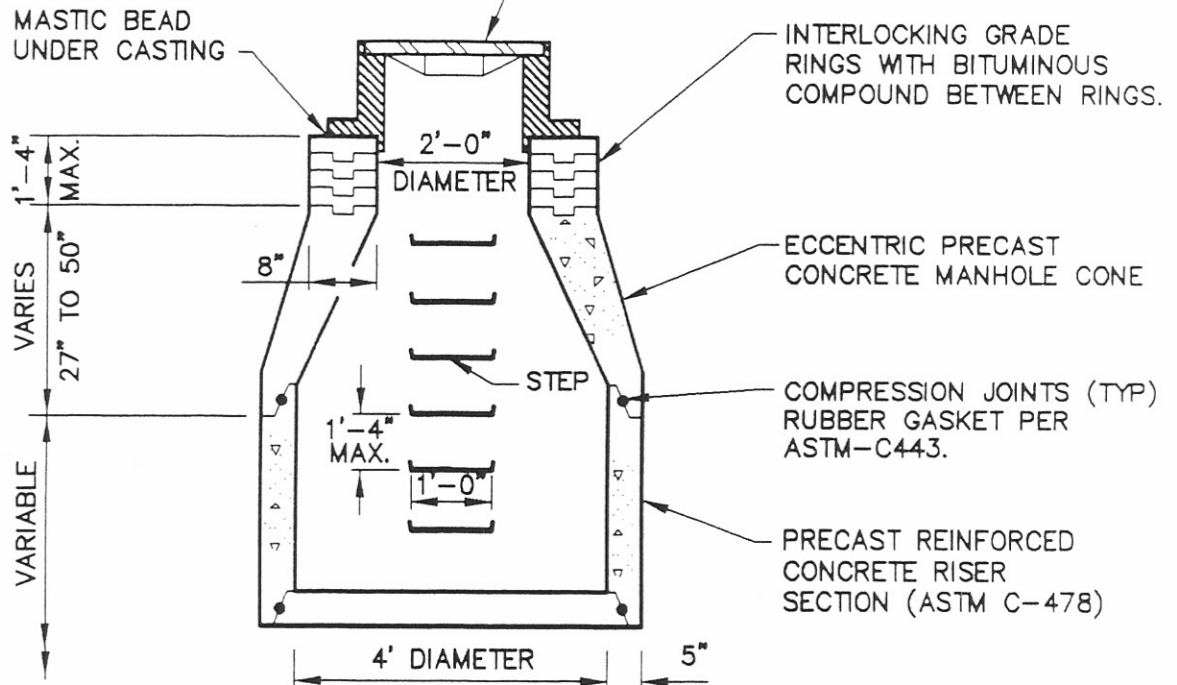

NOTES:

1. FOR MANHOLE BASES SEE SD-120 OR SD-121.
2. STEPS TO BE 1" SQUARE ALUMINUM OR MA INDUSTRIES #PSI-PF.
3. IN FLOOD PRONE AREAS, USE WATER TIGHT SOLID MANHOLE COVER NEENAH R-1915-H, OR EAST JORDAN #1600WT

CITY OF NEW PHILADELPHIA	STANDARD CONSTRUCTION DRAWING NO. <b>SD-119</b> REV. 08-00
PRECAST CONCRETE MANHOLE DETAIL	

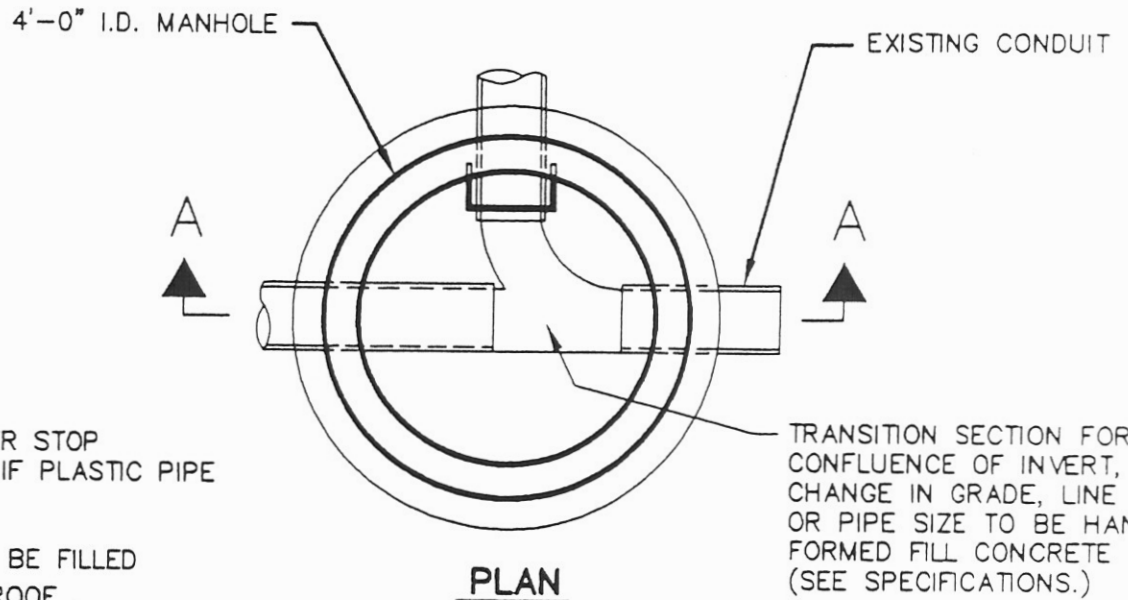

NOTES:

1. PROVIDE WATER STOP AROUND PIPE IF PLASTIC PIPE IS USED.
2. ALL VOIDS TO BE FILLED WITH WATERPROOF NONSHRINKING GROUT.
3. FOR ADDITIONAL MANHOLE DETAILS, SEE SD-119.

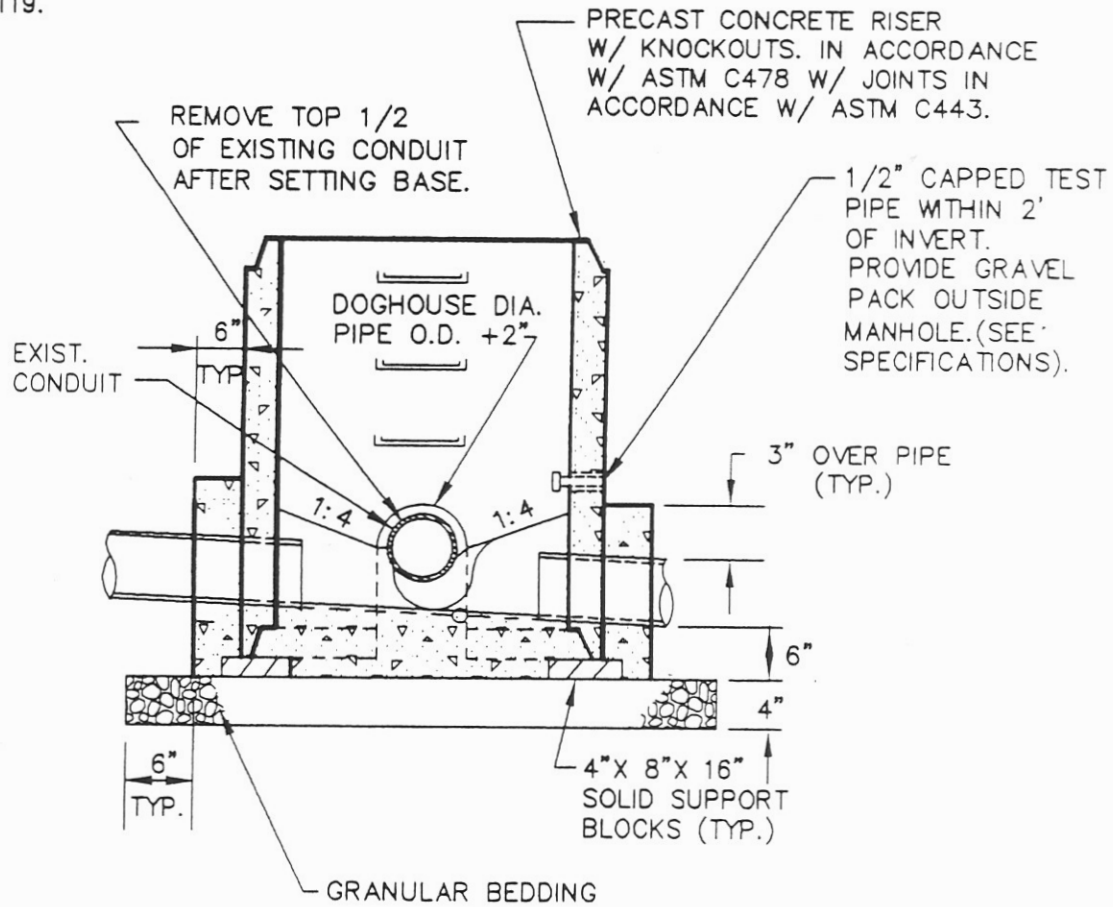

**SECTION A-A**

CITY OF NEW PHILADELPHIA		STANDARD CONSTRUCTION DRAWING NO. <b>SD-120</b> REV. 1-94
CAST IN PLACE CONCRETE MANHOLE BASE DETAIL		

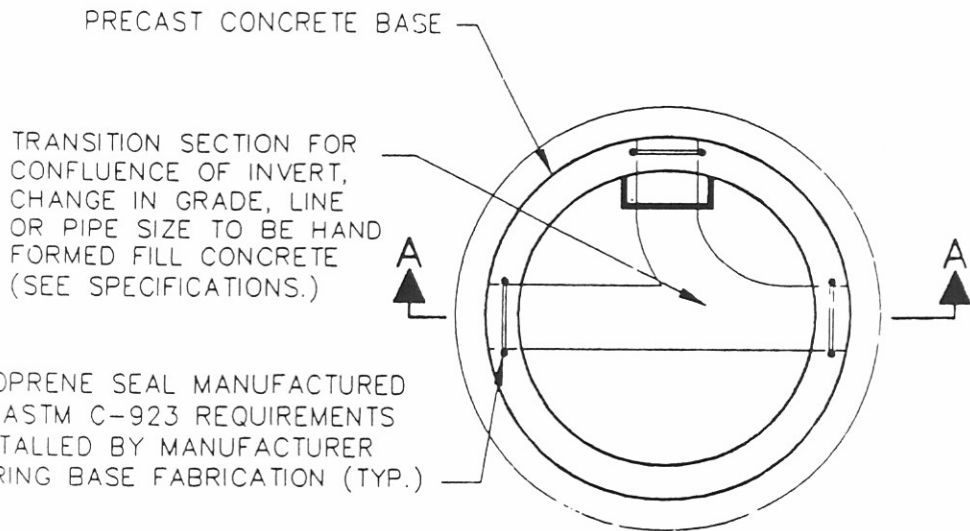

NEOPRENE SEAL MANUFACTURED TO ASTM C-923 REQUIREMENTS INSTALLED BY MANUFACTURER DURING BASE FABRICATION (TYP.)

NOTES:

1. FOR ADDITIONAL MANHOLE DETAILS, SEE SD-119.
2. ALL CHANNELS AND SLOPES TO BE HAND FORMED PRIOR TO INSTALLATION OF MANHOLE.
3. INVERT CHANNEL GRADES NOT TO EXCEED GRADES ON ENTERING AND EXITING PIPE RUNS.

PLAN

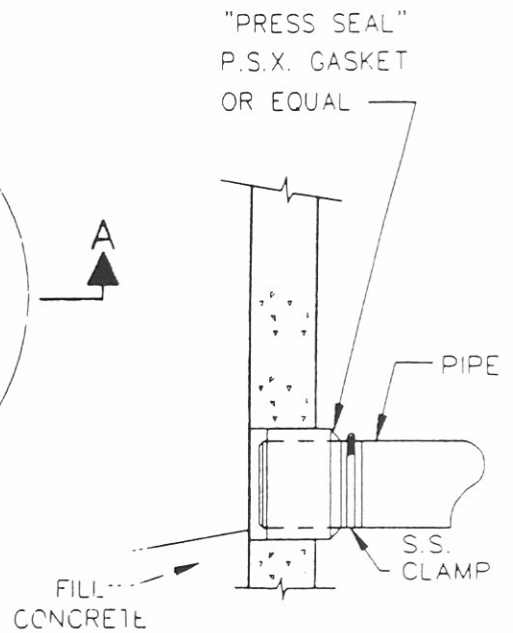

ALTERNATE GASKET

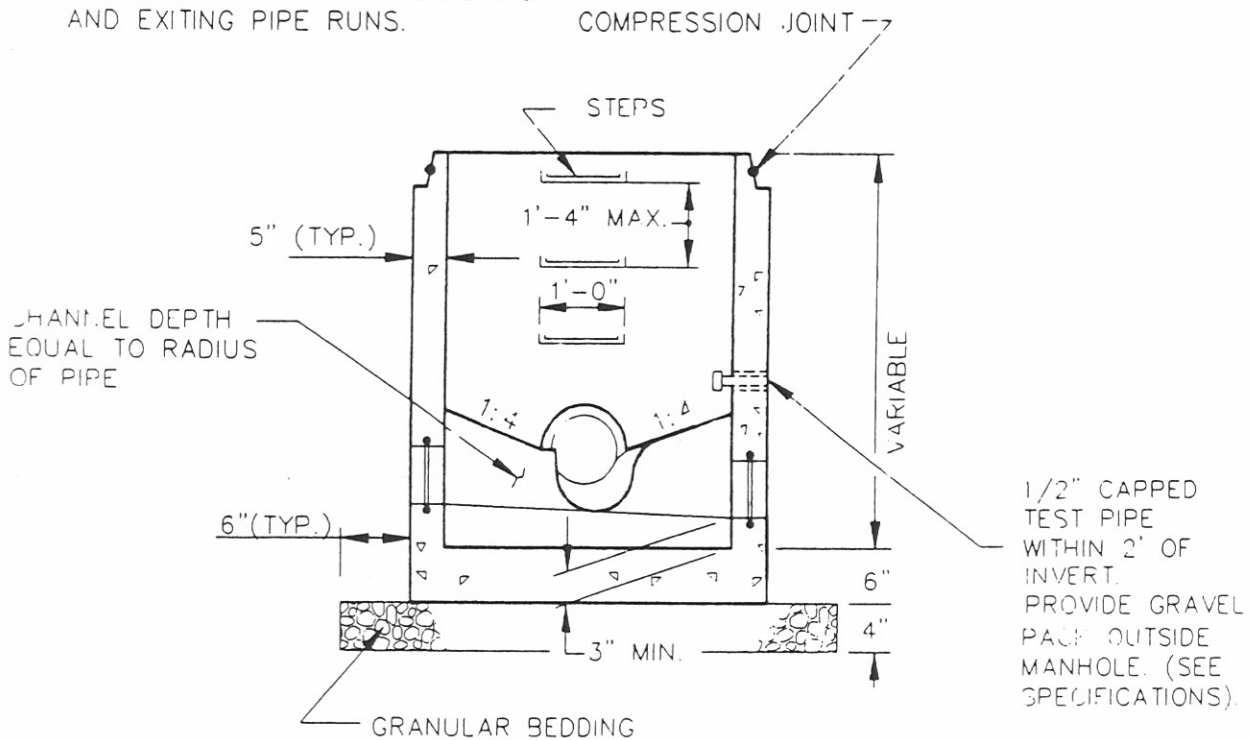

SECTION A-A

CITY OF NEW PHILADELPHIA	STANDARD CONSTRUCTION DRAWING NO
PRECAST MONOLITHIC CONCRETE MANHOLE BASE DETAIL	SD-121
	REV 1-94

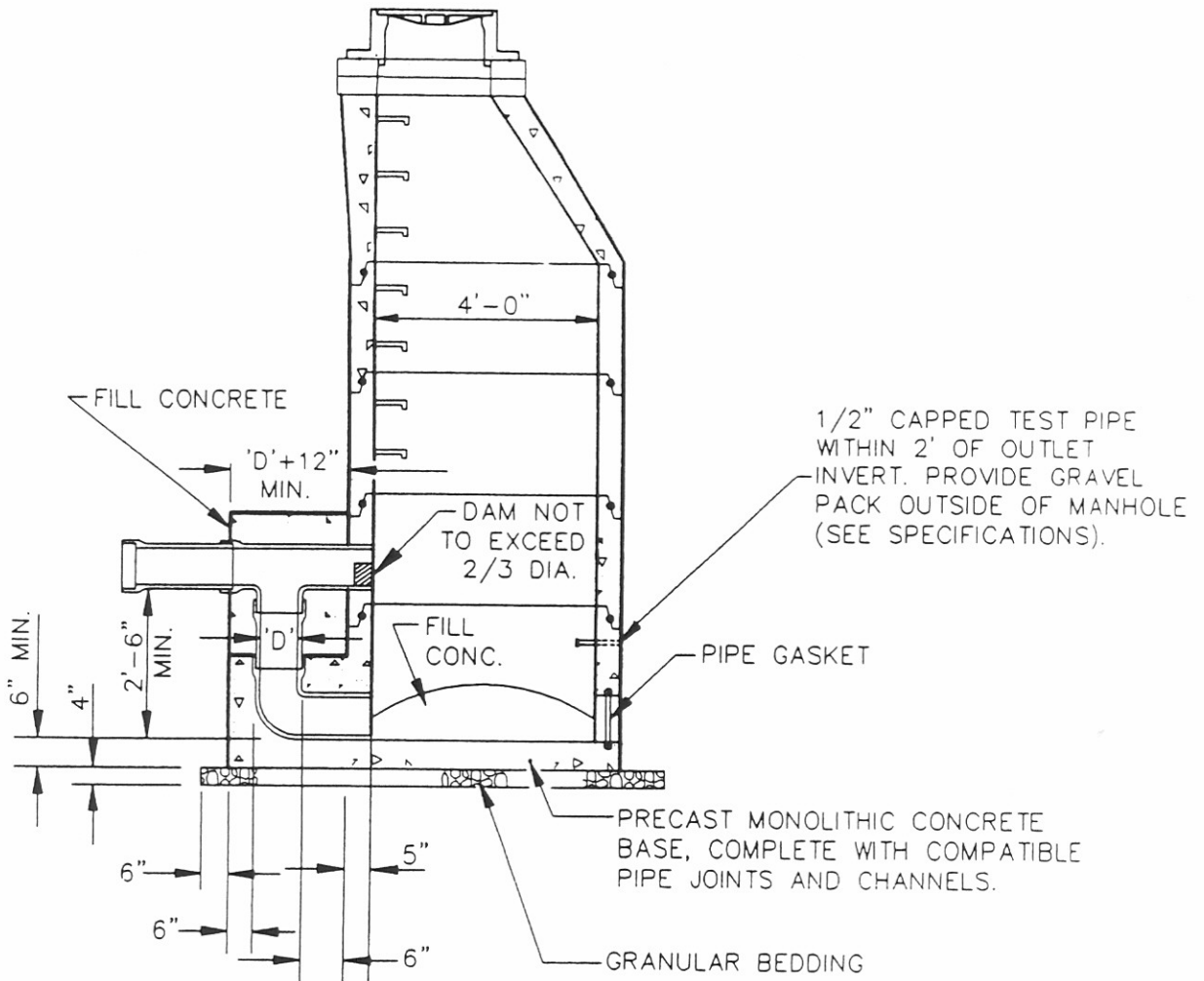

NOTES:

1. FOR ADDITIONAL BASE INFORMATION, SEE PRE-CAST MONOLITHIC BASE DETAIL FOR DROP MANHOLES, SD-123.
2. PROVIDE WATER STOP AROUND PIPE IF PLASTIC PIPE IS USED.
3. FOR ADDITIONAL MANHOLE INFORMATION, SEE PRECAST CONCRETE MANHOLE DETAIL SD-119.

<p>CITY OF NEW PHILADELPHIA</p>	<p>STANDARD CONSTRUCTION DRAWING NO.</p>
<p>DROP MANHOLE DETAIL WITH PRECAST MONOLITHIC BASE</p>	<p>SD-122</p>
	<p>REV. 1-94</p>

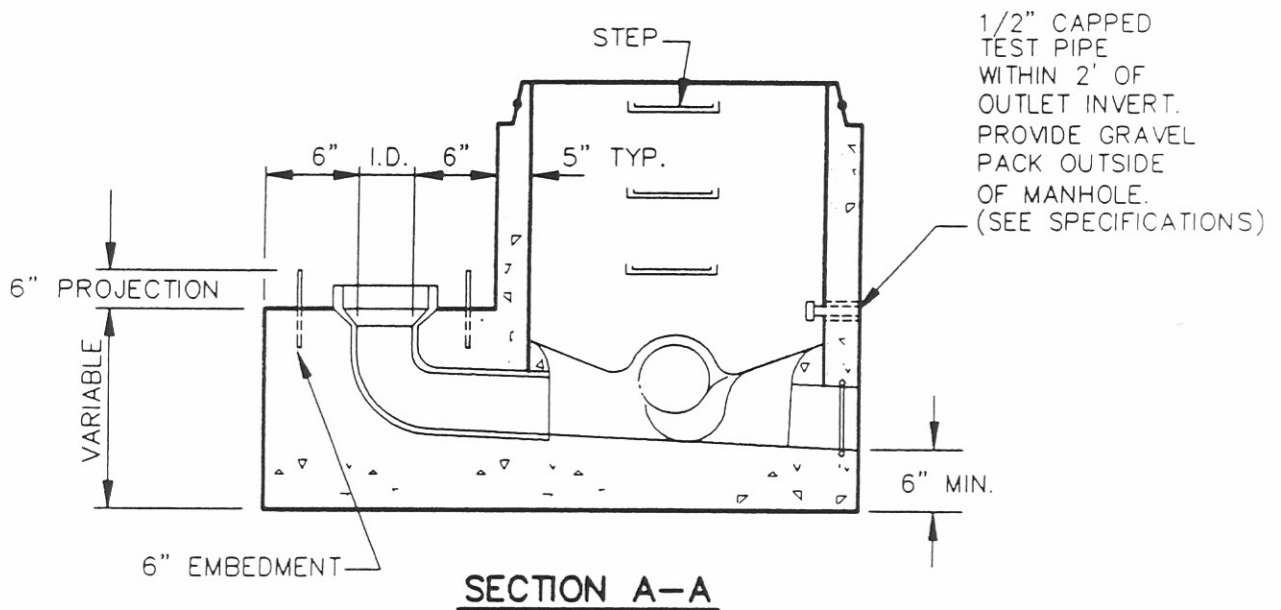
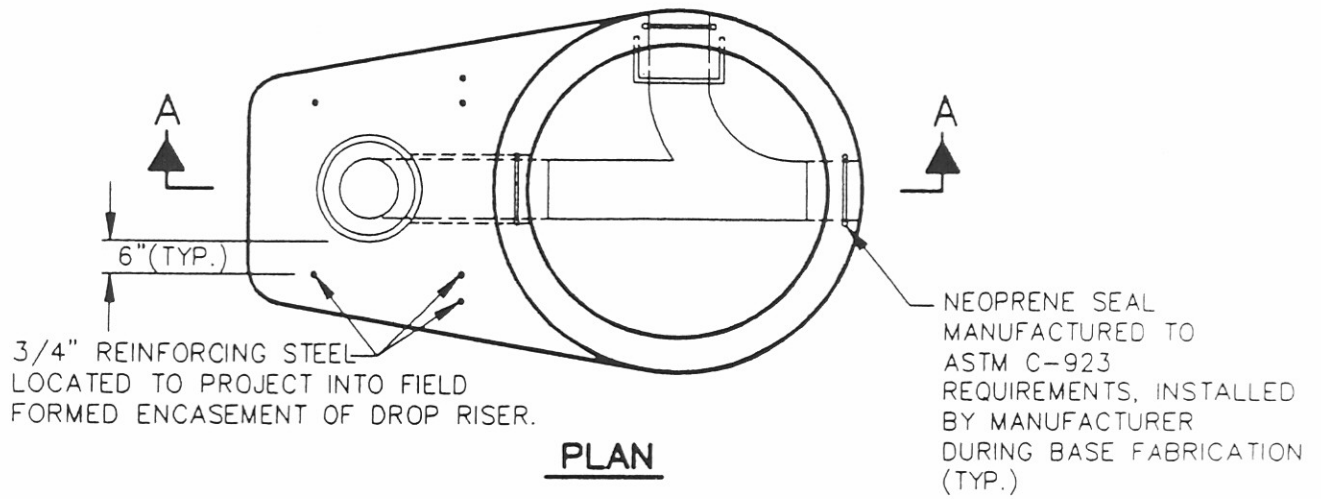

NOTES:

1. INVERT CHANNEL GRADES NOT TO EXCEED GRADES ON ENTERING AND EXITING PIPE RUNS.
2. ALL VOIDS TO BE FILLED WITH WATERPROOF NONSHRINKING GROUT.
3. FOR ADDITIONAL MANHOLE DETAILS, SEE SD-119.

<p><b>CITY OF NEW PHILADELPHIA</b></p> <p><b>PRECAST MONOLITHIC BASE DETAIL FOR DROP MANHOLES</b></p>	<p>STANDARD CONSTRUCTION DRAWING NO</p> <p><b>SD-123</b></p> <p>REV. 1-94</p>
---	---

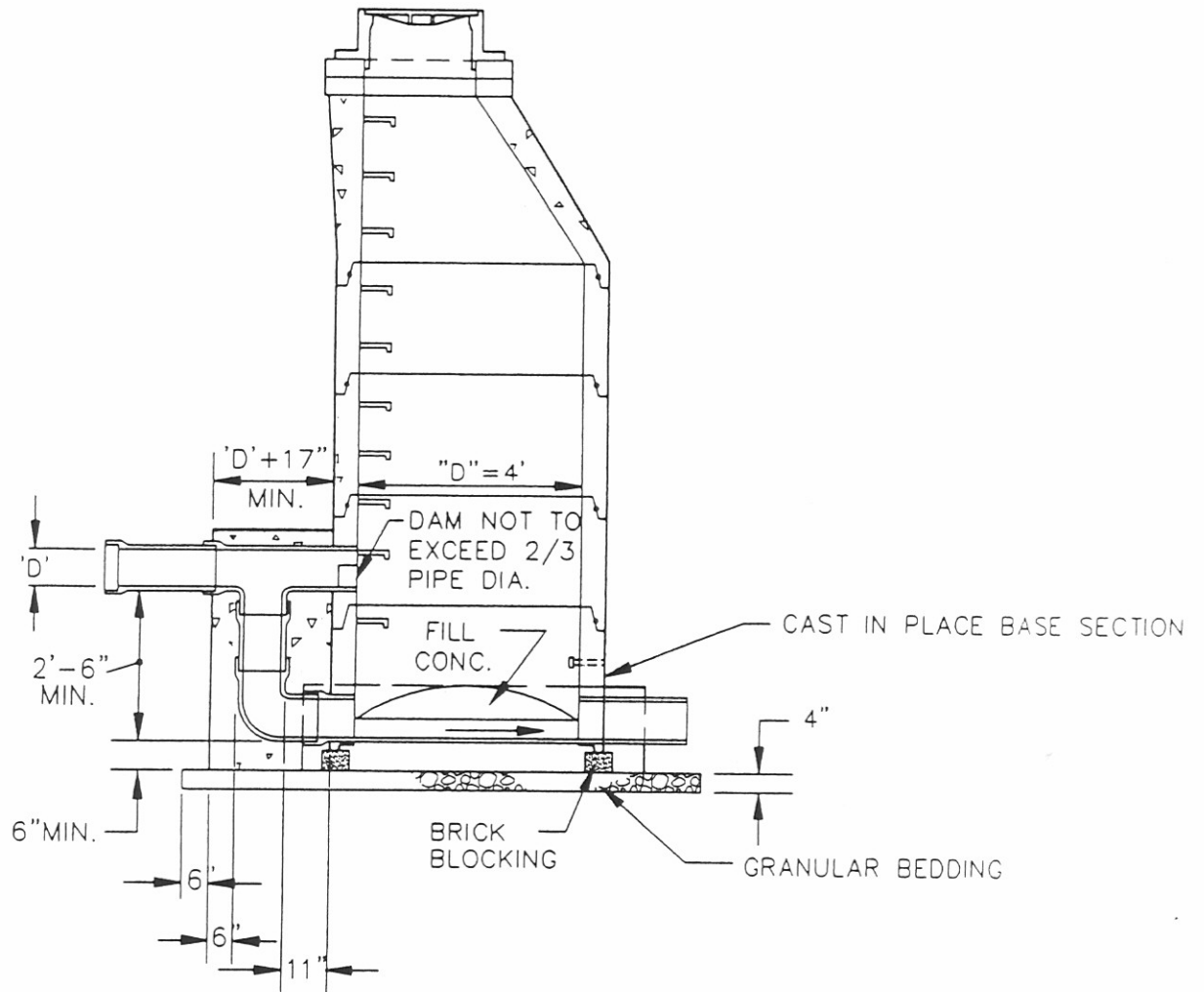

NOTES:

1. PROVIDE WATER STOP AROUND PIPE IF PLASTIC PIPE IS USED.
1. FILL ALL VOIDS WITH WATERPROOF NON-SHRINKING GROUT.
3. FOR ADDITIONAL BASE INFORMATION, SEE SD-121.
4. FOR ADDITIONAL MANHOLE INFORMATION, SEE SD-119.

CITY OF NEW PHILADELPHIA

DROP MANHOLE DETAIL  
WITH CAST IN PLACE BASE

STANDARD  
CONSTRUCTION  
DRAWING NO.

SD-124

REV. 1-94

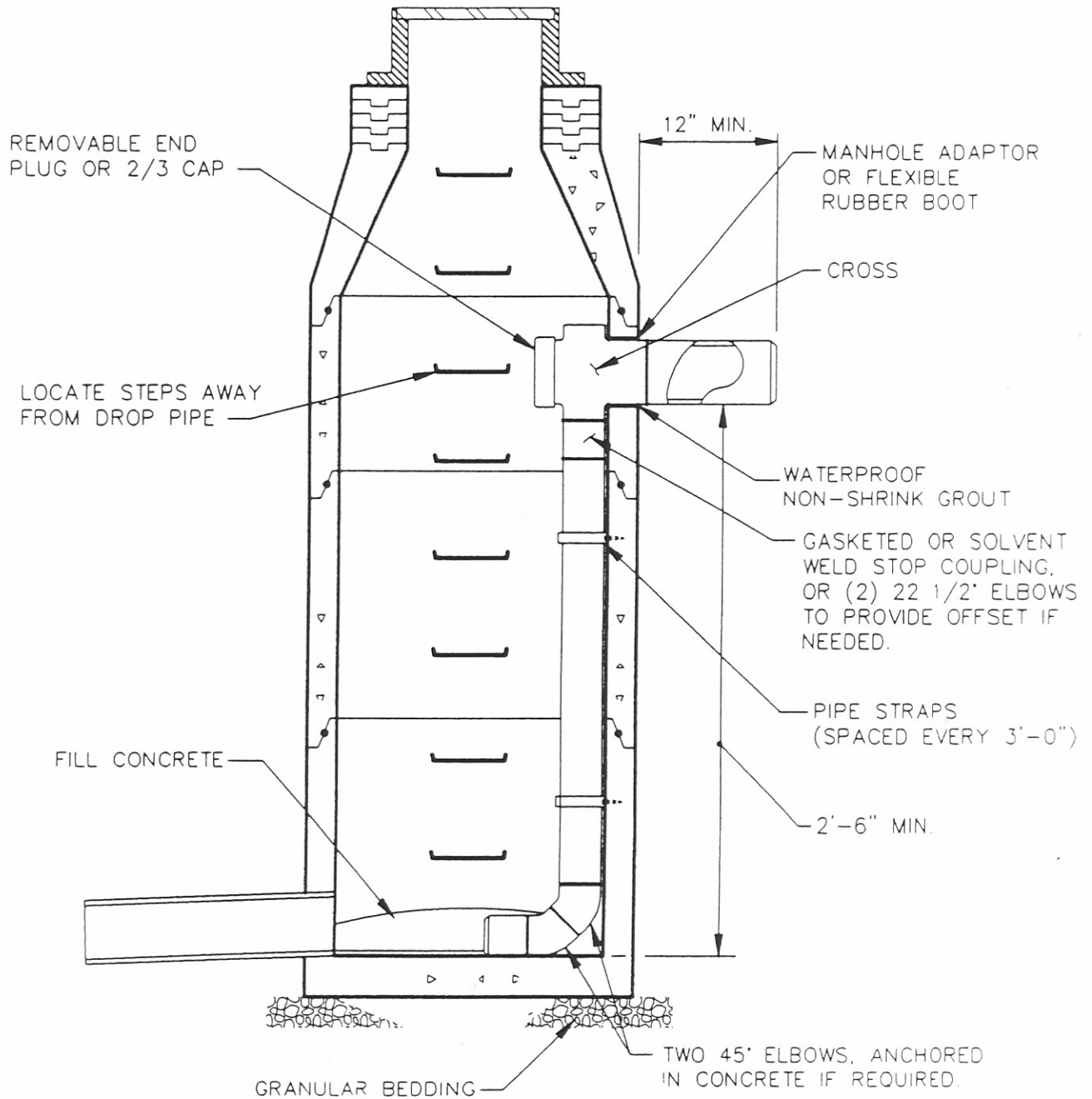

NOTE:  
 FOR ADDITIONAL MANHOLE AND BASE INFORMATION,  
 SEE SPECIFICATIONS AND THE FOLLOWING STANDARD  
 DETAILS, AS APPLICABLE: SD-119 THRU SD-121

CITY OF NEW PHILADELPHIA	STANDARD CONSTRUCTION DRAWING NO.
INSIDE DROP MANHOLE DETAIL	SD-125 REV. 1-94

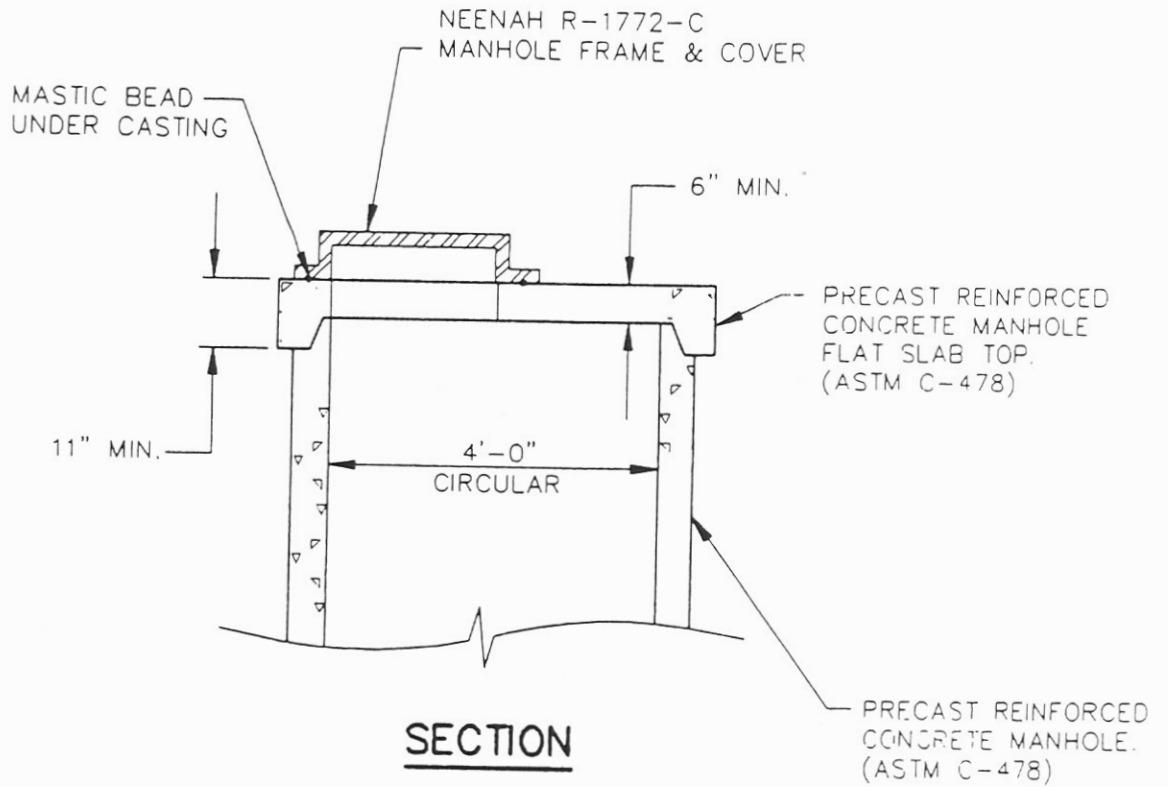

NOTES:

1. USE A SHALLOW MANHOLE ONLY WHEN THE DISTANCE FROM MANHOLE TOP TO SPRINGLINE OF OUTLET PIPE IS 5'-0" OR LESS.
2. FOR ADDITIONAL MANHOLE BASE INFORMATION SEE SPECIFICATIONS AND THE FOLLOWING STANDARD DETAILS, AS APPLICABLE, SD-120 & SD-121.

CITY OF NEW PHILADELPHIA	STANDARD CONSTRUCTION DRAWING NO.
PRECAST SHALLOW MANHOLE TOP	SD-126 REV. 1-94



NEENAH R-1772-C OR EAST JORDAN 1022-2  
 MANHOLE FRAME AND SOLID COVER WITH  
 WORDS "STORM SEWER" OR "SANITARY SEWER"  
 AS APPROPRIATE CAST IN RAISED LETTERS.

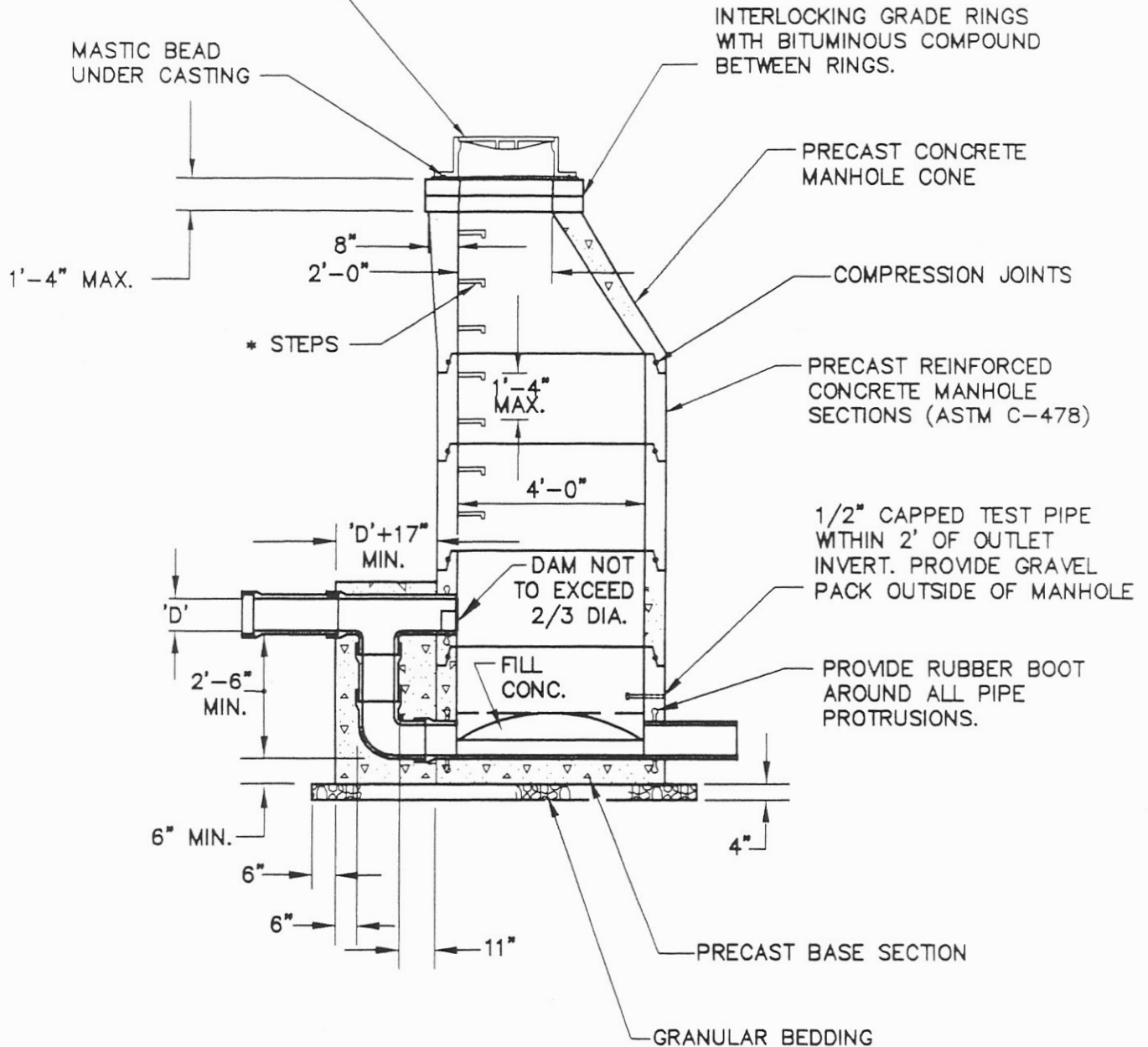

NOTES:

1. ALL VOIDS TO BE FILLED WITH WATERPROOF NON-SHRINKING GROUT.
2. FOR ADDITIONAL BASE INFORMATION, SEE PRE-CAST CONCRETE MANHOLE BASE DETAIL SD-122.
3. IN FLOOD PRONE AREAS, USE WATER TIGHT SOLID MANHOLE COVER NEENAH R-1915-H, OR EAST JORDAN #1600WT

\* STEEL REINFORCED PLASTIC STEPS MEETING ASTM D4101, TYPE II, GRADE 49108. MA INDUSTRIES # PSI-PF OR EQUAL.

<p>CITY OF NEW PHILADELPHIA</p> <p>DROP MANHOLE DETAIL          WITH PRECAST BASE AND PRECUT HOLES</p>	<p>STANDARD          CONSTRUCTION          DRAWING NO.</p> <p>SD-127</p> <p>REV. 08-00</p>
--	--

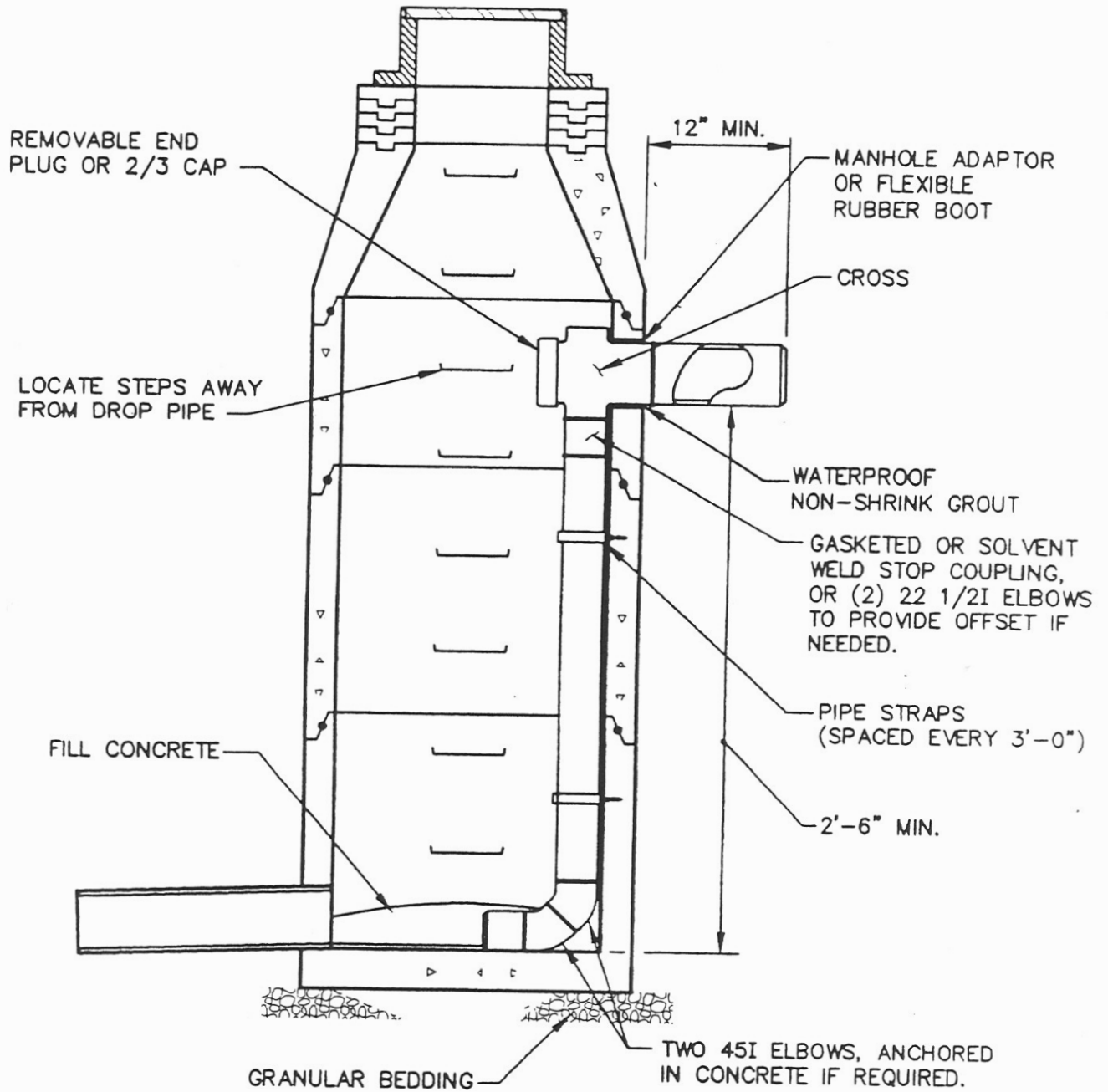

NOTE:  
 FOR ADDITIONAL MANHOLE AND BASE INFORMATION,  
 SEE SPECIFICATIONS AND THE FOLLOWING STANDARD  
 DETAILS, AS APPLICABLE: SD-119 THRU SD-127.

CITY OF NEW PHILADELPHIA	STANDARD CONSTRUCTION DRAWING NO.
INSIDE DROP MANHOLE DETAIL	SD-128 REV. 6-92

NO. 2-2-B CATCH BASIN (SINGLE)

BASIN: ODOT STANDARD NO. 2-2-B PRECAST CATCH BASIN.  
CASTING: "NEENAH" NO. R-4859-C. TYPE 'A' GRATE.  
ALTERNATE CASTING: "EAST JORDAN" NO. 5110. TYPE M3 GRATE.

NO. 3A CATCH BASIN (CURB-SINGLE)

BASIN: ODOT STANDARD NO. 3A PRECAST CATCH BASIN.  
CASTING: "NEENAH" NO. R-3289-C WITH CURB PLATE AND "DR" OR "DL" GRATE.  
ALTERNATE CASTING: "EAST JORDAN" NO. 7350 WITH CURB PLATE AND  
TYPE M2 DIAGONAL BAR GRATING.

NO. 3 CATCH BASIN (CURB-DOUBLE)

BASIN: ODOT STANDARD NO. 3 PRECAST CATCH BASIN.  
CASTINGS: (2) "NEENAH" R-3288-E2 WITH 2 PIECE GRATE AND CURB PLATE.  
PROVIDE "DR" OR "DL" GRATES.  
ALTERNATE CASTINGS: "EAST JORDAN" NO. 7355 WITH CURB PLATE AND  
TYPE M2 DIAGONAL BAR GRATING.

STANDARD CATCH BASIN SPECIFICATIONS

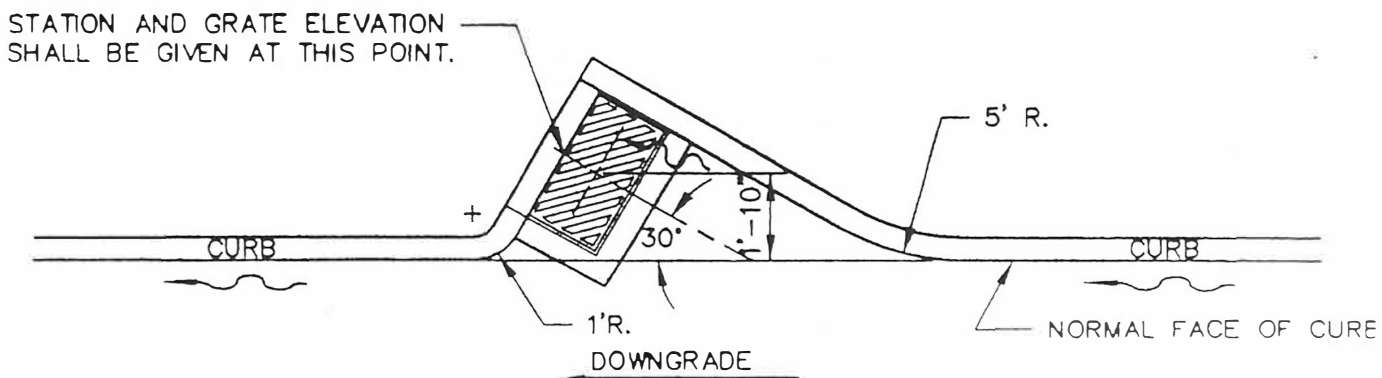

NOTES:

CASTINGS AND CONCRETE BASIN TO BE ODOT STANDARD 3A CATCH BASIN. CONCRETE APRON SHALL BE MODIFIED TO INCLUDE ALL THE AREA FROM NORMAL CURB LINE TO THE FACE OF CURB. PAYMENT FOR ALL LABOR AND MATERIALS SHALL BE INCLUDED IN UNIT PRICE BID PER STANDARD 3A CATCH BASIN, AND SHALL BE PERFORMED AS DIRECTED BY THE ENGINEER.

HILLSIDE CATCH BASIN DETAIL

CITY OF NEW PHILADELPHIA		STANDARD CONSTRUCTION DRAWING NO.
CATCH BASIN STANDARDS FOR PAVED CURB AREAS		SD-130
		REV. 3-99

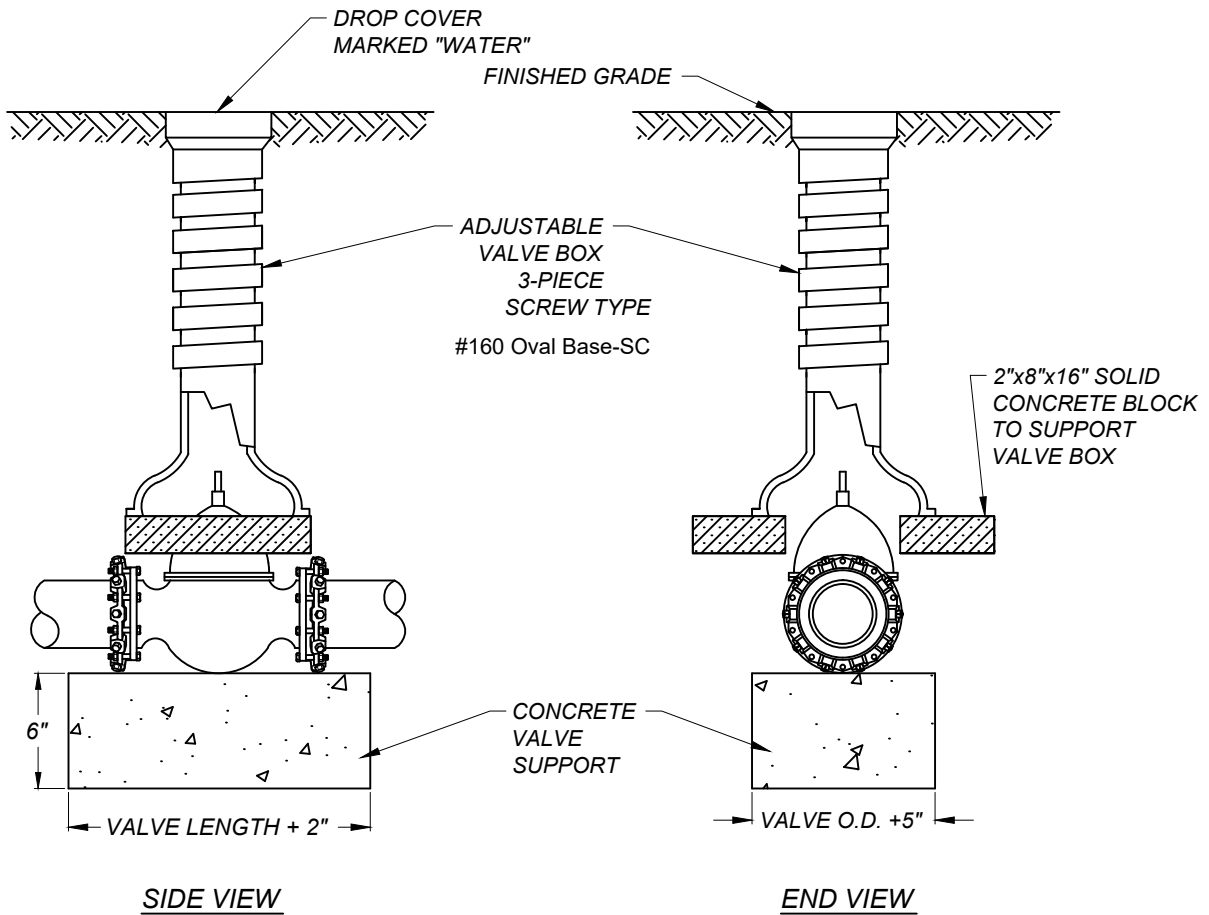

**CITY OF NEW PHILADELPHIA**

**TYPICAL VALVE  
AND VALVE BOX SETTING**

STANDARD  
CONSTRUCTION  
DRAWING NO.  
**SD-132**  
REV. 11-2021

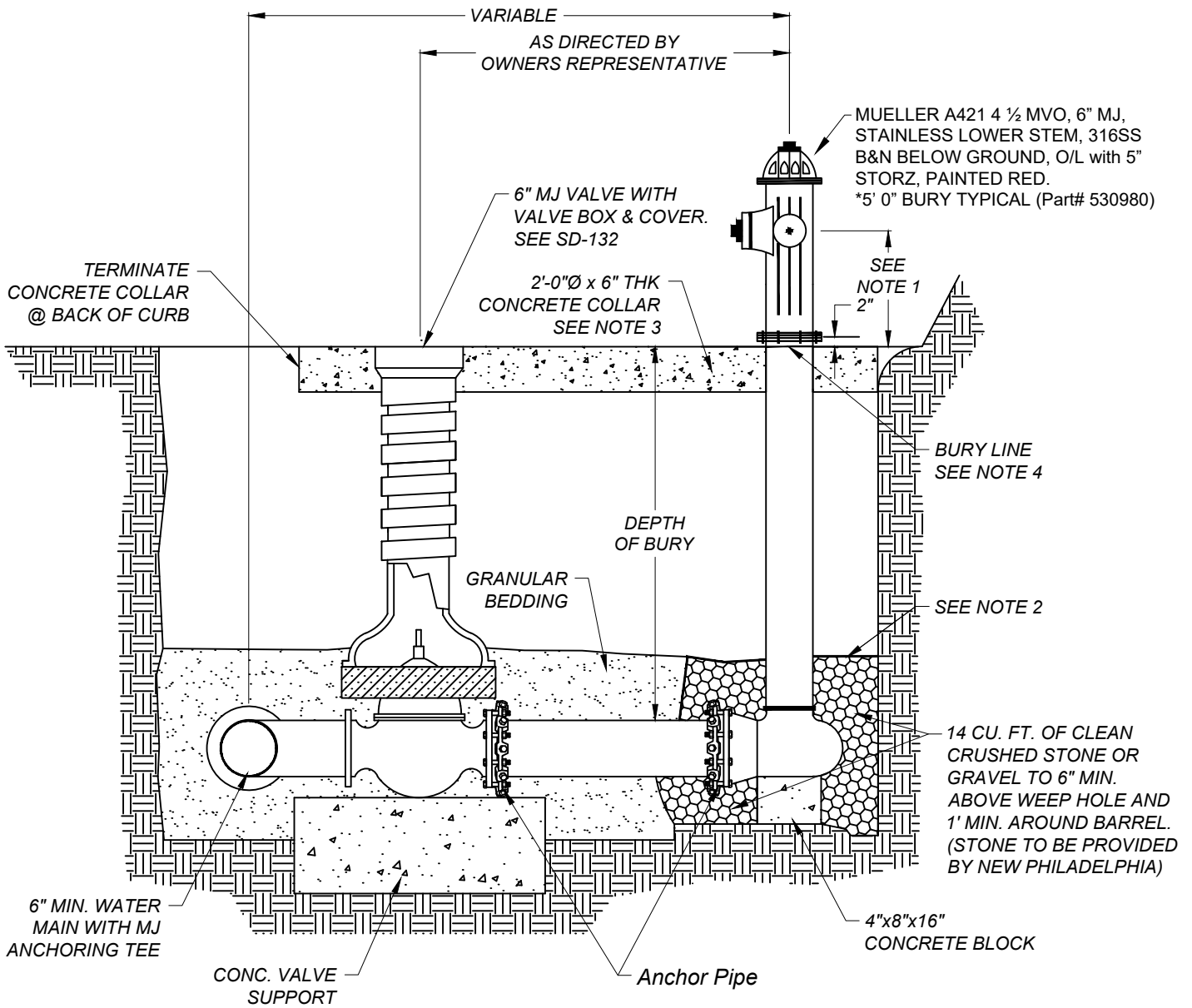

NOTES:

1. TO BE 12" MIN. OR AS RECOMMENDED BY HYDRANT MANUFACTURER.
2. COVER STONE WITH 8-MIL POLYETHYLENE BEFORE BACKFILLING.
3. CONCRETE COLLAR SHALL BE FLUSH WITH GROUND IN RURAL AREAS AND 8" BELOW FINISH GRADE IN RESIDENTIAL AREAS.
4. SET BURY LINE ON HYDRANT ASSEMBLY AT THE TOP CONCRETE COLLAR.

**CITY OF NEW PHILADELPHIA**

**FIRE HYDRANT ASSEMBLY  
WITH VALVE AND VALVE BOX**

STANDARD  
CONSTRUCTION  
DRAWING NO.

**SD-133**

REV. 11-2021

CURB BOX TO BE FLUSH WITH FINISH GRADE AND PROVIDED WITH A BOLT LOCKABLE COVER MARKED WITH WORD "WATER" FORMED IN LID.

CURB BOX AND CURB STOP TO BE LOCATED AS SHOWN ON PLAN VIEW

FINISH GRADE

3/4" & 1" - SIGMA (OR EQUIVALENT) SHORT 93E OR LONG 94E SHAFT SCREW SERVICE BOX  
2" - SIGMA (OR EQUIVALENT) 143R 4 1/2 SHAFT SCREW SERVICE BOX

**NOTE:**

PROVIDE A LOOP WITH SUFFICIENT SLACK TO PREVENT SERVICE LINE FROM BUCKING OR PULLING OUT OF CORPORATION STOP DURING BACKFILLING AND SETTLING OF TRENCH

**3/4" & 1" Service Fittings**

1. H-15000N Corp Stop (under 100psi)
2. B-25000N 300 Series Ball Corp Stop (over 100psi)
3. H-15067N Quarter Bend coupling 90° 110 Cond. Comp x Female Copper Flare Thread
4. H-15076N Quarter Bend Coupling 90° 110 Cond. Comp x Swivel Nut Female Copper Flare Thread

**2" Service Fittings**

1. Mueller BR2B Series Bronze Double Strap Service Saddle 6" - 14" Main
2. H-9968N 2" Corp Stop
3. H-15533N 2" Quarter Bend Coupling 90° 110 Cond. Comp x FIP Thread

42" MINIMUM

3/4" & 1" - MUELLER H-15000N FOR STATIC PRESSURE UNDER 100PSI  
3/4" & 1" MUELLER 300 SERIES BALL B-25000N FOR STATIC PRESSURES OVER 100PSI  
2" - MUELLER H-9968N CORPORATION STOP

90° COUPLING  
H-15067N 3/4" OR  
H15076N 3/4" & 1"

MUELLER H15209N  
CURB STOP 3/4", 1", &  
2"

PROTECTIVE CAP OR PLUG

WATER MAIN

SERVICE LINE - TYPE K COPPER  
3/4" - 2" DIAMETER CONTINUOUS RUN (NO SPLICES)

4"x8"x16" CONCRETE BLOCK VALVE SUPPORT

**CITY OF NEW PHILADELPHIA**

**TYPICAL SERVICE LINE AND SERVICE STOP SETTING**

STANDARD CONSTRUCTION DRAWING NO.

**SD-139**

REV. 05-2022

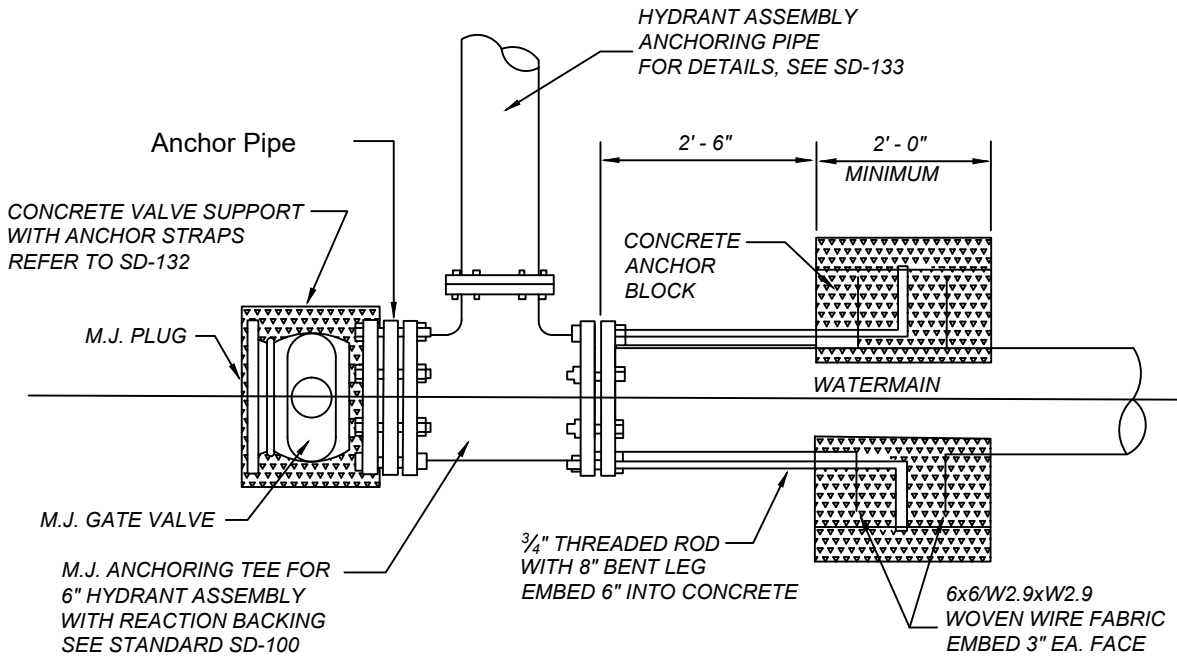

**PLAN VIEW**

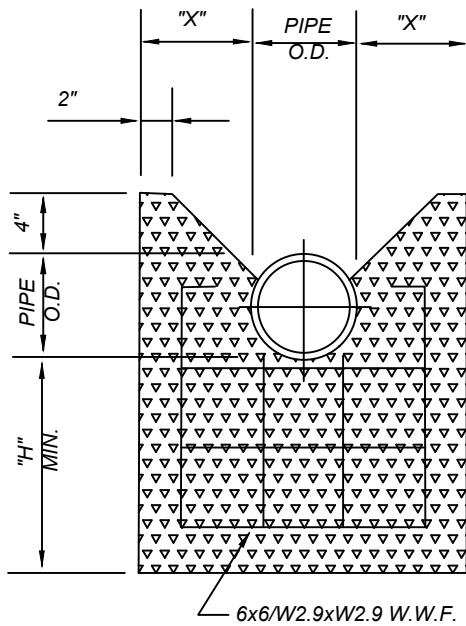

**ANCHOR BLOCK  
FACE VIEW**

**\*Stainless Rod & Hardware  
THREADED RODS REQUIRED**

- 6" - USE 2 THREADED RODS
- 8" - USE 3 THREADED RODS
- 10" - USE 3 THREADED RODS
- 12" - USE 4 THREADED RODS

THREADED RODS TO BE EQUALLY SPACED IN CONCRETE DEADMAN 2" MIN. CLEARANCE TO CONC. FACE

PIPE O.D.	"X"	"H"
6"	8"	1' - 0"
8"	10"	1' - 3"
10"	12"	1' - 5"
12"	16"	1' - 9"

NOTE: MAXIMUM AMOUNT OF SURFACE AREA OF ANCHOR BLOCK FACE TO REST AGAINST UNDISTURBED SOIL AS POSSIBLE.

WRAP WATERMAIN IN PLASTIC WHERE IN CONTACT WITH CONCRETE ANCHOR BLOCK.

**CITY OF NEW PHILADELPHIA**

TYPICAL END OF WATERLINE DETAIL

STANDARD  
CONSTRUCTION  
DRAWING NO.

**SD-140**

11-2021